

SLM-Series Plug-In DC Electronic Load Module Operation Manual

SORENSEN Power Supplies
Elgar Electronics Corporation
9250 Brown Deer Road
San Diego, CA 92121-2294
1-800-73ELGAR (1-800-733-5427)
Tel: (858) 450-0085
Fax: (858) 458-0267
Email: sales@sorensen.com
www.sorensen.com

©2005 by Sorensen, Division of Elgar Electronics Corporation
This document contains information proprietary to Sorensen, Elgar Electronics Corporation. The information contained herein is not to be duplicated or transferred in any manner without prior written permission from Sorensen.

SAFETY NOTICE

Before applying power to the system, verify that the SL Series is configured properly for the user's particular application.



WARNING!

HAZARDOUS VOLTAGES IN EXCESS OF 300 VRMS, 600V PEAK MAY BE PRESENT WHEN COVERS ARE REMOVED. QUALIFIED PERSONNEL MUST USE EXTREME CAUTION WHEN SERVICING THIS EQUIPMENT. CIRCUIT BOARDS, TEST POINTS, AND OUTPUT VOLTAGES MAY BE FLOATING ABOVE (BELOW) CHASSIS GROUND.

Installation and service must be performed by qualified personnel who are aware of dealing with attendant hazards..

Ensure that the AC power line ground is connected properly to the SL Series input connector or chassis. Similarly, other power ground lines including those to application and maintenance equipment must be grounded properly for both personnel and equipment safety.



During normal operation, the operator does not have access to hazardous voltages within the chassis. However, depending on the user's application configuration, HIGH VOLTAGES HAZARDOUS TO HUMAN SAFETY may be generated normally on the input terminals. Ensure that the input power lines are labeled properly as to the safety hazards and that any inadvertent contact with hazardous voltages is eliminated. To guard against risk of electrical shock during open cover checks, do not touch any portion of the electrical circuits. Even when the power is off, capacitors can retain an electrical charge. Use safety glasses during open cover checks to avoid personal injury by any sudden failure of a component.

Some circuits are live even with the front panel switch turned off. Service, fuse verification, and connection of wiring to the chassis must be accomplished at least five minutes after power has been removed via external means; all circuits and/or terminals to be touched must be safety grounded to the chassis.

After the unit has been operating for some time, the metal in a module may be hot enough to cause injury. Let the unit cool before handling.

These operating instructions form an integral part of the equipment and must be available to the operating personnel at all times. All the safety instructions and advice notes are to be followed.

Neither Elgar Electronics Corporation, San Diego, California, USA, nor any of the subsidiary sales organizations can accept any responsibility for personal, material or consequential injury, loss or damage that results from improper use of the equipment and accessories.

SAFETY SYMBOLS



CAUTION
Risk of Electrical Shock



CAUTION
Refer to Accompanying Documents



Off (Supply)



Direct Current (DC)



Standby (Supply)



Alternating Current (AC)



On (Supply)



Three-Phase Alternating Current



Protective Conductor Terminal



Earth (Ground) Terminal



Fuse



Chassis Ground

SORENSEN ONE-YEAR WARRANTY

Sorensen, a division of Elgar Electronics Corporation, warrants its products to be free from defects in material and workmanship. This warranty is effective for one year from the date of shipment of the product to the original purchaser. Liability of Sorensen under this warranty shall exist provided that:

- the Buyer exposes the product to normal use and service and provides normal maintenance on the product;
- Sorensen is promptly notified of defects by the Buyer and that notification occurs within the warranty period;
- the Buyer receives a Return Material Authorization (RMA) number from Sorensen's Repair Department prior to the return of the product to Sorensen for repair, phone 800-73ELGAR (1-800-733-5427);
- the Buyer returns the defective product in the original, or equivalent, shipping container;
- if, upon examination of such product by Sorensen it is disclosed that, in fact, a defect in materials and/or workmanship does exist, that the defect in the product was not caused by improper conditions, misuse, or negligence; and,
- that Sorensen QA seal and nameplates have not been altered or removed and the equipment has not been repaired or modified by anyone other than Sorensen authorized personnel.

This warranty is exclusive and in lieu of all other warranties, expressed or implied, including, but not limited to, implied warranties of merchantability and fitness of the product to a particular purpose. Sorensen, its agents, or representatives shall in no circumstance be liable for any direct, indirect, special, penal, or consequential loss or damage of any nature resulting from the malfunction of the product. Remedies under this warranty are expressly limited to repair or replacement of the product.

CONDITIONS OF WARRANTY

- To return a defective product, contact a Sorensen representative or the Sorensen factory for an RMA number. Unauthorized returns will not be accepted and will be returned at the shipper's expense.
- For Sorensen products found to be defective within thirty days of receipt by the original purchaser, Sorensen will absorb all ground freight charges for the repair. Products found defective within the warranty period, but beyond the initial thirty-day period, should be returned prepaid to Sorensen for repair. Sorensen will repair the unit and return it by ground freight pre-paid.
- Normal warranty service is performed at Sorensen during the weekday hours of 7:30 am to 4:30 pm Pacific time. If the request is made to have the warranty repair work accomplished outside of normal working hours, Sorensen non-warranty service rates will apply.
- Warranty field service is available on an emergency basis. Travel expenses (travel time, per diem expense, and related air fare) are the responsibility of the Buyer. A Buyer purchase order is required by Sorensen prior to scheduling.
- A returned product found, upon inspection by Sorensen, to be in specification is subject to an inspection fee and applicable freight charges.
- Equipment purchased in the United States carries only a United States warranty for which repair must be accomplished at the Sorensen factory.

Sorensen

Power Evolved

ABOUT THIS MANUAL

This manual has been written expressly for the Sorensen SL series of electronic loads, which have been designed and certified to meet the Low Voltage and Electromagnetic Compatibility Directive Requirements of the European Community.

Since the goal of the Low Voltage Directive is to ensure the safety of the equipment operator, universal graphic symbols have been used both on the unit itself and in this manual to warn the operator of potentially hazardous situations (see Safety Symbols on page ii).

CONTENTS

SECTION 1	Introduction, Features and Specifications	1-1
1.1	GENERAL DESCRIPTION	1-1
1.1.1	POWER CONTOURS	1-1
1.1.2	OPERATING MODES	1-4
1.2	FEATURES	1-7
1.2.1	ACCESSORIES	1-7
1.3	MODULE SPECIFICATIONS	1-8
1.4	REGULATORY COMPLIANCE	1-9
1.5	BLOCK DIAGRAM	1-9
SECTION 2	Installation and Maintenance	2-1
2.1	INSTALLATION AND REMOVAL OF SLM-SERIES DC PLUG IN MODULE	2-2
2.1.1	INSTALLATION	2-2
2.1.2	REMOVAL	2-3
2.2	CONNECTIONS	2-3
2.2.1	INPUT BINDING POST AND WIRE CONSIDERATIONS	2-3
2.2.2	TYPICAL CONNECTIONS	2-4
2.2.3	THE CONNECTION FOR A MULTIPLE OUTPUT POWER SUPPLY	2-4
2.3	MAINTENANCE	2-5
2.3.1	CLEANING AND STORAGE	2-5
SECTION 3	Operation	3-1
3.1	FRONT PANEL CONTROLS AND INDICATORS	3-1
3.1.1	DESCRIPTION	3-1
3.1.2	SUMMARY CHART	3-6

3.2	OPERATION – SETUP AND OCP/OPP TESTS	3-7
3.2.1	OVERVIEW OF FRONT PANEL OPERATION	3-7
3.2.2	INITIAL SETUP (LIMIT KEY).....	3-7
3.2.3	NORMAL OPERATING MODES	3-11
3.2.4	INITIAL SETTING OF SLM-SERIES DC LOAD MODULES	3-16
3.2.5	ANALOG PROGRAMMING INPUT	3-16
3.2.6	LOAD COARSE/FINE INCREASE/DECREASE ADJUSTMENT KEY	3-17
3.2.7	I-MONITOR	3-18
3.2.8	PROTECTION FEATURES	3-19

SECTION 4 Applications.....4-1

4.1	LOCAL SENSE CONNECTIONS.....	4-1
4.2	REMOTE SENSE CONNECTIONS	4-2
4.3	CONSTANT CURRENT (CC) MODE APPLICATION	4-3
4.3.1	STATIC MODE:	4-3
4.3.2	DYNAMIC MODE:.....	4-4
4.4	CONSTANT VOLTAGE (CV) MODE APPLICATION.....	4-5
4.5	CONSTANT RESISTANCE (CR) MODE APPLICATION.....	4-6
4.6	CONSTANT POWER (CP) MODE APPLICATION.....	4-7
4.7	PARALLEL OPERATION	4-8

SECTION 5 Remote Programming.....5-1

5.1	GPIB COMMANDS.....	5-1
5.2	RS-232 INTERFACE AND COMMANDS	5-1
5.3	GPIB/RS-232C COMMAND LIST	5-2
5.3.1	COMMAND SYNTAX ABBREVIATIONS	5-2
5.4	GPIB/RS-232 COMMAND DESCRIPTION	5-7
5.4.1	SETTING COMMANDS.....	5-7
5.4.2	QUERY COMMANDS.....	5-20

APPENDIX A SLM-SERIES DC LOAD GPIB/RS-232 OPERATING FLOW CHART..... A

LIST of TABLES

TABLE 1-1	SLM-SERIES DC LOAD MODULE SPECIFICATION	1-8
TABLE 3-1	SLM-SERIES DC ELECTRONIC LOAD FACTORY SETTINGS FOR POWER ON.....	3-16
TABLE 3-2	RESOLUTION OF RANGE I/II VS COARSE/FINE LOAD CURRENT SETTING KEYS.....	3-18

TABLE 3-3 SUMMARY OF OVER PROTECTION VALUES	3-20
TABLE 5-1 GPIB COMMAND TERMINATOR.....	5-3
TABLE 5-2 GPIB/RS-232 SETTING COMMAND SUMMARY.....	5-4
TABLE 5-3 GPIB/RS-232 PRESET QUERY COMMAND SUMMARY WITH APPLICABLE MODULE TYPES	5-4
TABLE 5-4 STATE COMMAND SUMMARY	5-5
TABLE 5-5 SYSTEM COMMANDS - ALL MODULES	5-6
TABLE 5-6 MEASURE AND LIMIT COMMANDS	5-6
TABLE 5-7 GLOBAL COMMANDS.....	5-6
TABLE 5-8 WAVEFORM INFORMATION	5-14

LIST of FIGURES

FIGURE 1-1 SLM-60-30-150 POWER CONTOUR	1-1
FIGURE 1-2 SLM-60-60-300 POWER CONTOUR.....	1-2
FIGURE 1-3 SLM-250-10-300 POWER CONTOUR.....	1-2
FIGURE 1-4 SLM-500-10-300 POWER CONTOUR.....	1-3
FIGURE 1-5 SLM-60-15-75 POWER CONTOUR	1-3
FIGURE 1-6 CONSTANT CURRENT (CC) MODE.....	1-4
FIGURE 1-7 CONSTANT RESISTANCE (CR) MODE	1-4
FIGURE 1-8 CONSTANT VOLTAGE (CV) MODE.....	1-5
FIGURE 1-9 CONSTANT POWER (CP) MODE.....	1-5
FIGURE 1-10 DYNAMIC WAVEFORM.....	1-6
FIGURE 1-11 BLOCK DIAGRAM OF SLM-SERIES DC ELECTRONIC LOAD.....	1-9
FIGURE 2-1 BINDING POST AND SCREW ON SLM-SERIES DC PLUG-IN LOAD MODULE	2-1
FIGURE 2-2 PLUG-IN INSTALLATION AND REMOVAL.....	2-2
FIGURE 2-3 TYPICAL CONNECTIONS FOR SLM-SERIES DC SERIES LOAD MODULE.....	2-4
FIGURE 2-4 SLM-SERIES DC PLUG-IN LOAD AND MULTIPLE OUTPUT POWER SUPPLY CONNECTION ...	2-4
FIGURE 3-1 SLM-SERIES DC PLUG-IN MODULE FRONT PANEL	3-1
FIGURE 3-2 ORGANIZATION OF FRONT PANEL CONTROLS OF SLM-SERIES DC PLUG-IN MODULE	3-6
FIGURE 3-3 FLOWCHART FOR LOAD MODULE GENERAL SETUP PARAMETERS AND OCP AND OPP TESTS	3-10
FIGURE 3-4 DYNAMIC MODE WAVEFORM AND DEFINITION PARAMETERS.....	3-13
FIGURE 3-5 NORMAL OPERATING MODE FLOWCHART	3-15
FIGURE 3-6 ANALOG PROGRAMMING LOAD CURRENT IN CC MODE OPERATION.....	3-17
FIGURE 4-1 LOCAL VOLTAGE SENSE CONNECTIONS	4-1
FIGURE 4-2 REMOTE VOLTAGE SENSE CONNECTIONS	4-2
FIGURE 4-3 CONSTANT CURRENT MODE APPLICATION	4-3
FIGURE 4-4 DYNAMIC LOAD CURRENT WITH INDEPENDENT PROGRAMMED RISE/FALL SLEW RATE ...	4-4
FIGURE 4-5 CONSTANT VOLTAGE MODE APPLICATION.....	4-5
FIGURE 4-6 CONSTANT RESISTANCE ODE APPLICATION.....	4-6
FIGURE 4-7 CONSTANT POWER MODE APPLICATION.....	4-7
FIGURE 4-8 SLM-SERIES DC PLUG-IN LOAD MODULE PARALLEL OPERATION (TOP) SERIES CONNECTION NOT ALLOWED (BOTTOM).....	4-8
FIGURE 5-1 RS-232 INTERFACE DIAGRAM	5-2
FIGURE 5-2 PROTECTION STATUS REGISTER.....	5-23
FIGURE 5-3 ERROR STATUS BYTE REGISTER.....	5-23

SECTION 1 INTRODUCTION, FEATURES AND SPECIFICATIONS

1.1 General Description

The SLM-series DC electronic load module is designed for test, evaluation and burn-in of DC power supplies and batteries. This module must be operated in the SLM Electronic Load chassis, the mainframe whose front panel allows operation of its 150 store/recall setups and which has a remote control feature. All load modules in the mainframe simultaneously return to the previously stored memory when a recall operation is performed on the mainframe.

1.1.1 Power Contours

The power contours of SLM-series DC electronic loads are shown in Figure 1-1 through Figure 1-5.

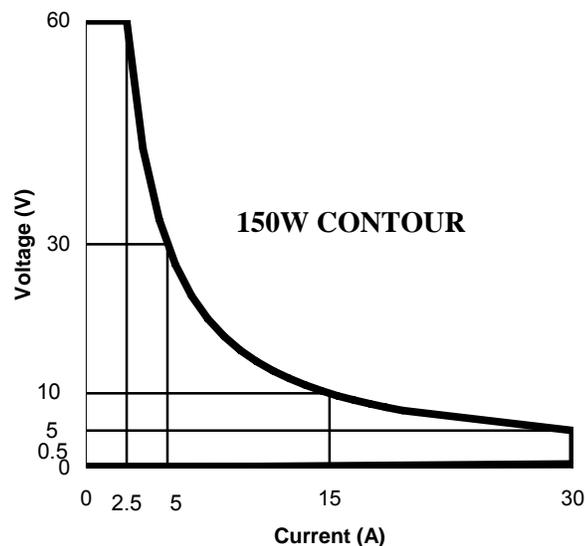

Figure 1-1 SLM-60-30-150 Power Contour

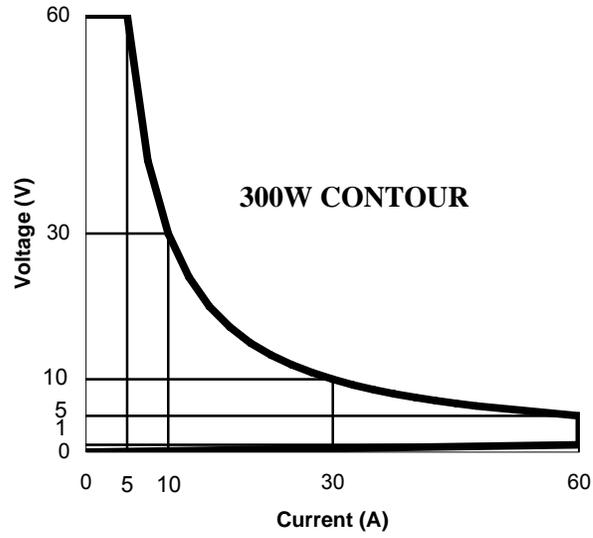

Figure 1-2 SLM-60-60-300 Power Contour

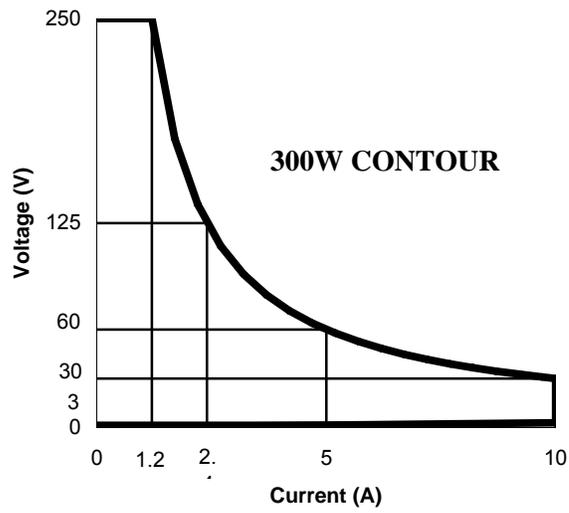

Figure 1-3 SLM-250-10-300 Power Contour

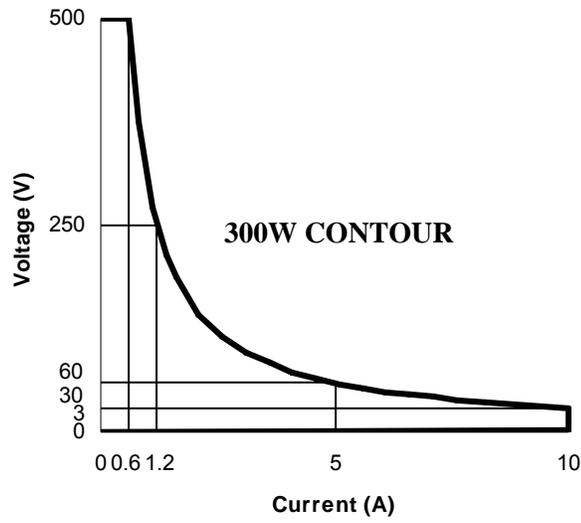

Figure 1-4 SLM-500-10-300 Power Contour

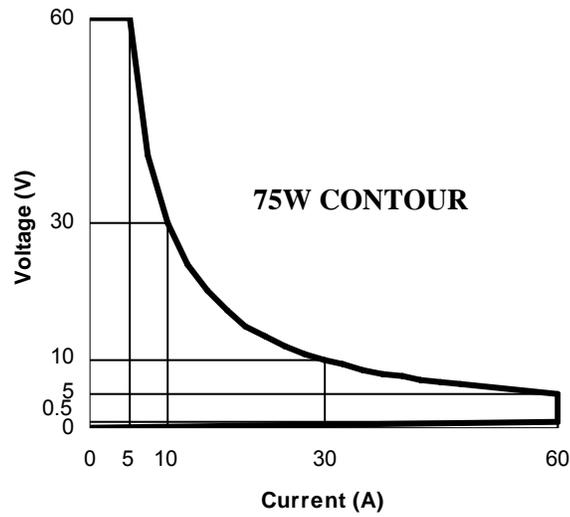

Figure 1-5 SLM-60-15-75 Power Contour

1.1.2 Operating Modes

The four operating modes of SLM-series DC electronic load include: Constant Current (CC) mode, Constant Resistance (CR) mode, Constant Voltage (CV) mode, and Constant Power (CP) mode. The wide-range dynamic load with independent rise/fall current slew rate and analog programming input with arbitrary waveform input, is available in Constant Current and Constant Power modes. This dynamic feature enables SLM-series DC electronic loads to simulate real world loads.

CC Mode:

In Constant Current mode, the load will sink a current in accordance with the programmed current setting regardless of the input voltage (see Figure 1-6).

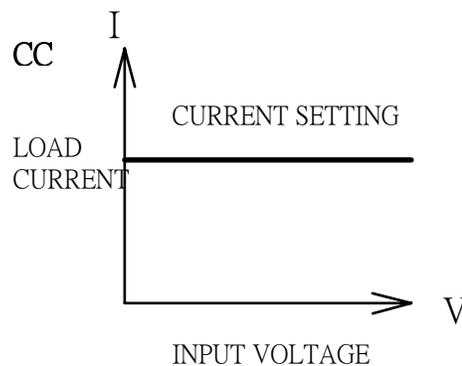

Figure 1-6 Constant Current (CC) Mode

CR Mode:

In Constant Resistance mode, the load will sink a current linearly proportional to the load input voltage in accordance with the programmed resistance setting (see Figure 1-7).

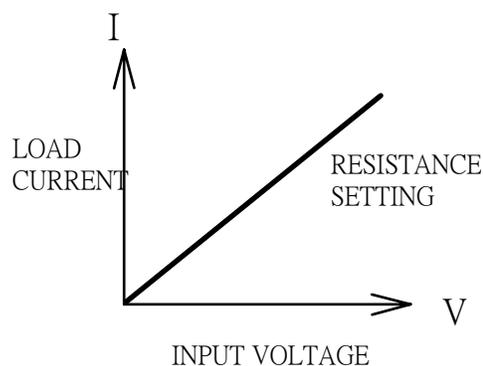

Figure 1-7 Constant Resistance (CR) Mode

CV Mode:

In Constant Voltage mode, the load will attempt to sink enough current to maintain the programmed voltage setting (see Figure 1-8).

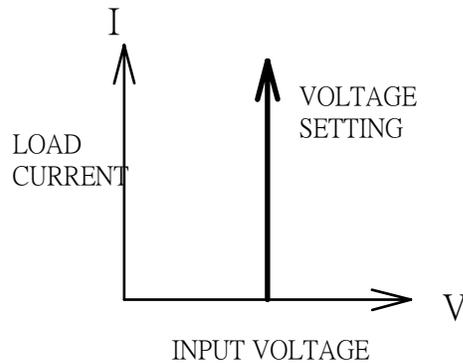

Figure 1-8 Constant Voltage (CV) Mode

CP Mode:

In Constant Power mode, the load will attempt to sink load power (load voltage x load current) in accordance with the programmed power setting. (see Figure 1-9).

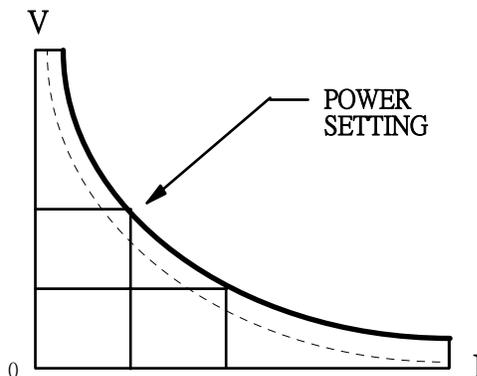

Figure 1-9 Constant Power (CP) Mode

Wide-Range Dynamic Load

The Dynamic load can simulate real-world load conditions, thereby providing relevant testing and evaluation for the power source products. Dynamic loading is available for CC (Constant Current) and CP (Constant Power) modes.

Dynamic Waveform Definition:

There are six parameters to generate a dynamic waveform or pulse waveform: High/Low load levels, Rise/Fall slew rates, and THIGH/TLOW durations. The SLM-series DC electronic Load will sink current from the power source, proportional to the dynamic waveform. The dynamic waveform definition is shown in Figure 1-10.

The formula to define the period of dynamic waveform is:

$$\text{Dynamic frequency} = 1 / (\text{THIGH} + \text{TLOW})$$

$$\text{Duty cycle} = \text{THIGH} / (\text{THIGH} + \text{TLOW})$$

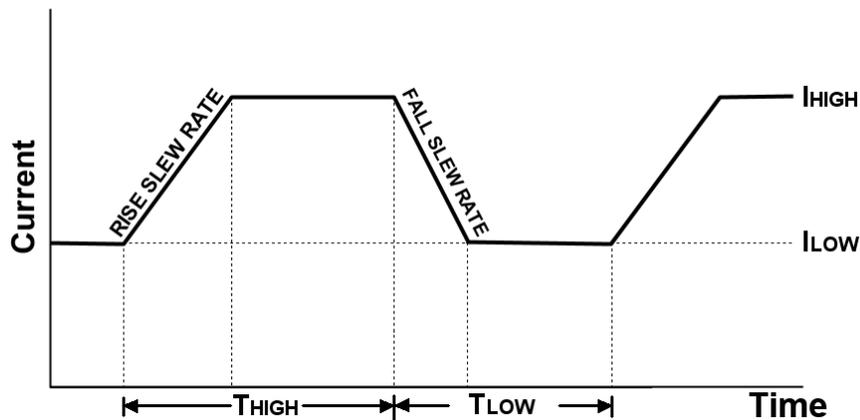

Figure 1-10 Dynamic Waveform

The load current level and load status can be set by any of three ways:

- on the front panel of each load module,
- through the mainframe store/recall memory, or
- with GPIB/RS-232 commands

The load input voltage and load current can be read back to the computer through GPIB or RS-232 bus. (See the SLM Mainframe Operation Manual for a description of the mainframe store/recall and GPIB/RS-232 remote operation).

1.2 Features

- Flexible configuration of plug-in Electronic Load module and mainframe
- CC, CR, CV, CP, Dynamic, and Short Operating Mode
- Remote control of Load condition setting and meter read back
- Dual high accuracy & resolution 16-bit voltage and current meter
- Built-in pulse generator includes wide THIGH/TLOW dynamic load range, independent Rise/Fall load current slew rate control, and High/Low Load level
- Controllable load current slew rate of load level change, load ON/OFF switch change, and power supply turn-on
- Short circuit test and current measure capability
- Programmable voltage sense capability
- Full protection from over power, over temperature, over voltage, and reverse polarity
- Analog programming input capability at each load module
- Isolated I-monitor BNC output, 10V full scale (except models with maximum voltage >100V)
- Digital calibration
- Variable fan speed control
- Up to 150 Sets Store/Recall EEPROM memory

1.2.1 Accessories

- V-sense cable: BNC-CLIP (1M) 1 ea.
- Binding Post Plug (Black) 1 ea.
- Binding Post Plug (Red) 1 ea.
- Hook terminal 2 ea.
- SLM-series operation manual 1 ea.
- High Voltage V-sense Cable: BNC-CLIP 1M (250 and 500V models) 1 ea.

1.3 Module Specifications

NOTE: The following specifications apply $25^{\circ}\pm 5^{\circ}$

MODEL	SLM-60-15-75		SLM-60-30-150		SLM-60-60-300		SLM-250-10-300		SLM-500-10-300	
INPUT RATING										
VOLTAGE	60V		60V		60V		250V		500V	
Current	15A		30A		60A		10A		10A	
POWER	75W		150W		300W		300W		200W	
MIN. VOLTAGE	1V @ 15A		1V @ 30A		1V @ 60A		3V @ 10A		5V @ 10A	
CC MODE										
Range 1 Range 2	0-1.5A	0-15A	0 - 3A	0 - 30A	0 - 6A	0 - 60A	0 - 1A	0 - 10A	0-1A	0-10A
Resolution	0.4mA	4.0mA	0.8mA	8.0mA	1.6mA	16mA	0.268mA	2.68mA	0.134mA	1.34mA
Accuracy	$\pm 0.2\%$, OF (SETTING + RANGE)									
CR MODE										
Range 1 Range 2	4-15K Ω	0.213-4 Ω	2-7.5K Ω	0.1067-2 Ω	1-3.75K Ω	0.0533-1 Ω	25-18.75K Ω	1.333-25 Ω	0.1-18.75K Ω	5.33-100 Ω
Resolution	66.66 μ S	1.066m Ω	0.133mS	0.533m Ω	0.266mS	0.266m Ω	0.053mS	6.666m Ω	13.333 μ S	26.66m Ω
Accuracy	$\pm 0.2\%$ OF (SETTING + RANGE)									
CV MODE										
Range	0 - 60V		0 - 60V		0 - 60V		0 - 250V		N/A	
Resolution	0.015V		0.016V		0.016V		0.0667V		N/A	
Accuracy	$\pm 0.1\%$ OF (SETTING + RANGE)									
CP MODE										
Range	0 - 75W		0 - 150W		0 - 300W		0 - 300 W		0 - 300W	
Resolution	0.02W		0.04W		0.08W		0.08W		0.08W	
Accuracy	$\pm 0.5\%$ OF (SETTING + RANGE)									
SHORT MODE										
Resistance	0.017 Ω		0.034 Ω		0.0167 Ω		0.08 Ω		0.43 Ω	
Current	15A		30A		60A		10A		10A	
DYNAMIC										
THIGH & TLOW	50 μ sec to 9.999 sec									
Rise/Fall (Range 1)	1.0-62.5 mA/ μ s		2.0-125 mA/ μ s		4-250 mA/ μ s		0.8-50 mA/ μ s		0.8-50 mA/ μ s	
	10-625 mA/ μ s		0.2-1.2 A/ μ s		0.04-2.5 A/ μ s		8.0-500 mA/ μ s		8.0-500 mA/ μ s	
Accuracy	$\pm (5\% + 10\mu$ s)									
4 1/2 DVM										
Range	15.0V	60.0V	15.0V	60.0V	15.0V	60.0V	30.0V	250.0V	60.0V	500.0V
Resolution	0.001V	0.002V	0.001V	0.002V	0.001V	0.002V	0.001V	0.01V	0.002V	0.02V
Accuracy	$\pm 0.05\%$ OF (READING + RANGE)									
4 1/2 DAM										
Range	1.5A	15.0A	3.0A	30.0A	6.0A	60.0A	1.2A	12.0A	1A	10.0A
Resolution	0.0001A	0.001A	0.001A	0.01A	0.001A	0.01A	0.0001A	0.001A	0.0001A	0.001A
Accuracy	$\pm 0.2\%$ OF (READING + RANGE)									
Imonitor	1.5 A/V		3.0 A/V		6.0 A/V		N/A		N/A	
Load ON Volt.										
Range	0.1 - 25V		0.1 - 25V				0.2 - 50V		0.4 - 100V	
Resolution	0.1V		0.1V				0.2V		0.4V	
Accuracy	1% of Setting + 0.25V		1% of Setting + 0.25V				1% + 0.5V		1% of Setting + 1V	
Load OFF Volt.										
Range	0 - 25V		0 - 25V				0 - 50V		0 - 100V	
Resolution	0.002V		0.002V				0.01V		0.02V	
Accuracy	0.05% of Setting + 0.0125V		0.05% of Setting + 0.0125V				0.05% of Setting + 0.025V		0.05% of Setting + 0.05V	

Table 1-1 SLM-series DC Load Module Specification

1.4 Regulatory Compliance

- Certified to UL 61010-1, CSA C22.2 No. 61010.1 and IEC/EN 61010-1
- CE Compliant:
 - Low Voltage Directive (73/23/EEC) using EN 61010-1, and
 - EMC Directive (89/336/EEC) using EN 61326
- FCC Compliant to 21 CFR, Subpart J.

1.5 Block Diagram

A functional block diagram of the SLM-series DC electronic Load module is illustrated in Figure 1-11. (Please refer to the SLM Mainframe Operation Manual for the functional block diagram of the mainframe).

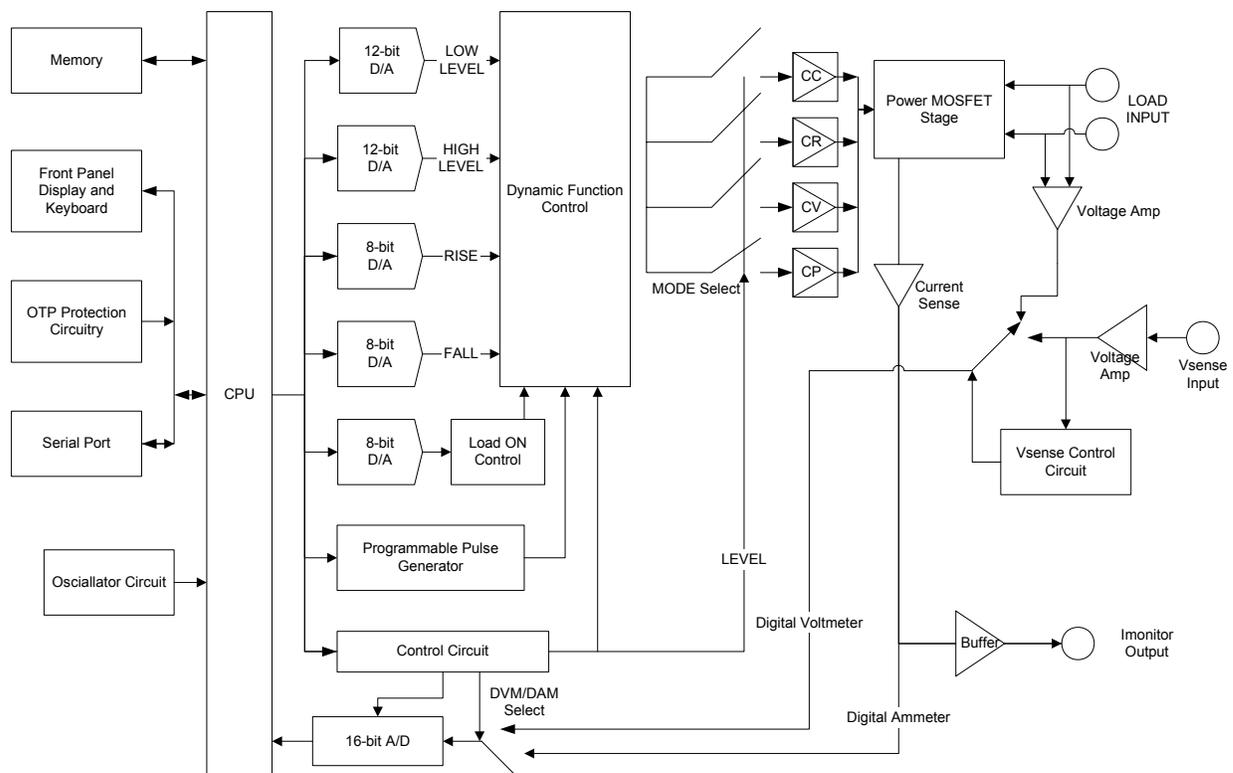

Figure 1-11 Block Diagram of SLM-Series DC Electronic Load

The isolated serial port of the SLM mainframe receives the remote programming load level status.

Six parameters (Hi/Low levels, Rise/Fall slew rates, THIGH/TLOW durations) constitute the wide range pulse generator, and can be used to test the power supply - Device Under Test (DUT).

The two 12-bit Digital/Analog (D/A) converters convert the programmed High/Low load level data to an analog signal, and then feed the signal to the input of static/dynamic function control circuit.

The two 8-bit D/A converters control the load current slew rate for Rise and for Fall slew rates.

The two 16-bit timers set THIGH and TLOW durations.

The Constant Current (CC), Constant Resistance (CR), Constant Voltage (CV) and Constant Power (CP) control and the Range circuitry are selected depending upon which operating mode and range are programmed. The drive circuit controls the load current flow through power MOSFET, which is proportional to the analog control signal. The load power energy is converted to heat and is dissipated on the heat sink.

The voltage sensing circuit selects the load input terminal or V-sense BNC input, depending on the V-sense setting.

The current sense amplifier feeds the load current signal to 16-bit DAM, which feeds the 5-digit LED display and isolated amplifier (I-Monitor BNC output).

The Auto-ranged 16-bit high accuracy digit voltage meter feeds the input voltage to the 5-digit LED display. The 16-bit voltage and current meter digital bus is connected to CPU circuitry. Each load module can transfer the meter readings to SLM mainframe through isolated serial circuitry.

SECTION 2 INSTALLATION AND MAINTENANCE

This section discusses the installation and removal procedures for the SLM-series DC load module and the SLM quad module mainframe. The SLM-series DC load module does not need any adjustment after plugging into the SLM mainframe.

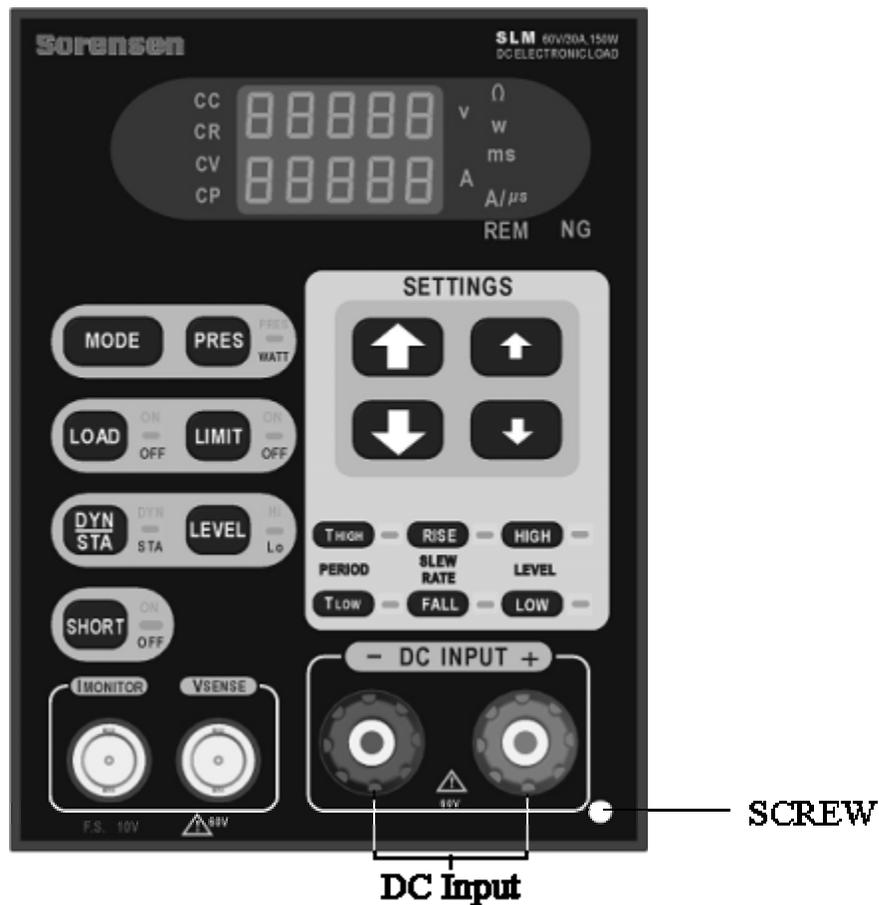

Figure 2-1 Binding Post and Screw on SLM-Series DC Plug-in Load Module

2.1 Installation and Removal of SLM-Series DC Plug in Module



CAUTION:
Only qualified personnel should do installation and removal.

Unless the SLM mainframe and the SLM-series DC electronic load module were purchased separately, the load module should be installed in the mainframe before shipment from Sorensen.

Installation and removal procedures for the SLM-series load module are listed below.

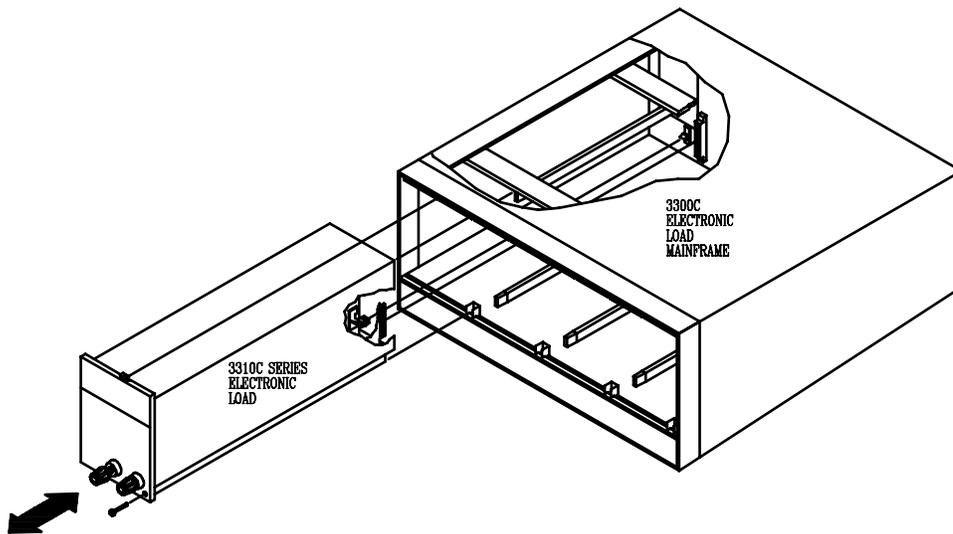

Figure 2-2 Plug-in Installation and Removal

2.1.1 Installation

- 1 **Turn the SLM mainframe power OFF** before inserting any load module, or damage may occur to the plug-in module circuitry.
2. Align the upper and lower grooves of the mainframe with the upper and lower guides of the selected compartment.
3. Push the module in and press firmly on the binding posts (labeled, “DC Input” in Figure 2-1) of the front panel to seat the circuit board into the interconnecting jack.
4. Using a screwdriver, tighten the screw on the lower right corner of the SLM-series load module front panel. The screw location is shown in Figure 2-1.
5. **DO NOT** turn the mainframe power ON until after all of the electronic modules are completely installed.

2.1.2 Removal



CAUTION: PREVENT DAMAGE TO THE MODULE CIRCUITRY. Do NOT remove the plug-in module while the mainframe is under power.

1. Turn the **SLM mainframe power OFF**.
2. Using a screwdriver, loosen the screw on the lower right corner of the front panel.
3. Turn the adjustment knob of the black binding post counter-clockwise until it is fully loosened.
4. Pull on the black adjustment knob of binding post until the interconnecting jack at the rear of the load module disengages.
5. Finish pulling the SLM-series DC load module out from the mainframe.

2.2 Connections

2.2.1 Input Binding Post and Wire Considerations

The output of the device under test (DUT) can be connected to the load by one of five methods, each described in the following subsections. The positive (+) and negative (-) binding posts should be connected to the wires/cables according to the following guidelines. A major consideration in making input connection is the wire size. The minimum wire size is required to prevent overheating and to maintain good regulation. It is recommended that the wires be large enough to limit the voltage drop to less than 0.5V per lead.

Note: When using Constant Resistance mode, Vsense inputs should be used to keep cable resistance from affecting measurements and regulation.



CAUTION: PREVENT DAMAGE TO THE LOAD. Do NOT apply voltage or current with power switched OFF. Turn ON the power switch to the load PRIOR to applying voltage or current to the input terminals (i.e., before turning on the power supply under test).

Plug Connectors

This is the most popular way to connect the input of electronic load to the device under test. It is recommended the load current be less than 20A in this connection since the current rating of the plug is rated to 20A. The maximum wire gauge should be limited to AWG14.

Hook Terminals

The hook terminal provides a good contact to the binding post and can be used anytime. The maximum wire gauge should be limited to AWG10.

Direct Insertion into Binding Posts

This is the most convenient way to connect the load input to the DUT. The maximum wire gauge AWG14 can be used in this application.

Plug Connectors and Hook Terminals

This method is recommended when input current is greater than 20A.

Plug Connectors and Direct Insertion

This method is also recommended when input current is greater than 20A.

2.2.2 Typical Connections

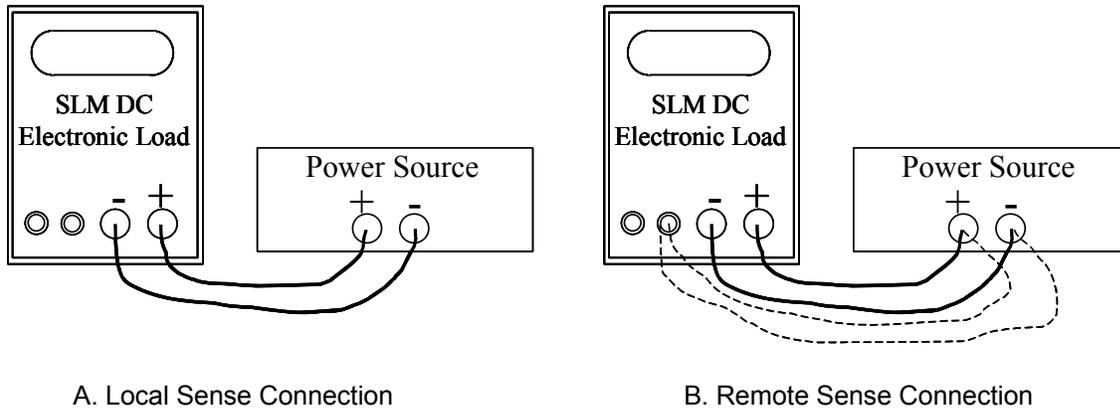

Figure 2-3 Typical Connections for SLM-Series DC Series Load Module

2.2.3 The Connection for a Multiple Output Power Supply

Rule for a multiple output power supply connection to the SLM-series DC electronic Loads:

The potential of positive input (Red binding post) must be higher than the potential of negative input (Black binding post) of SLM-series DC electronic load.

Figure 2-4 is an example of +5V, -5V, +12V, -12V and +24V six outputs power supply connected to a SLM-series DC electronic load.

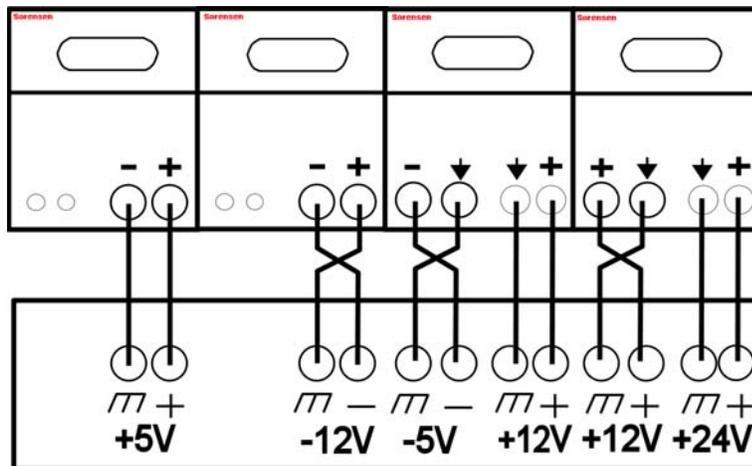

Figure 2-4 SLM-Series DC Plug-in Load and Multiple Output Power Supply Connection

2.3 Maintenance

2.3.1 Cleaning

**WARNING:**

To avoid electrical shock or damage to the meter, do not get water inside the case.

Periodically wipe the case with a damp cloth and detergent; do not use abrasives or solvents.

This page intentionally left blank.

SECTION 3 OPERATION

This section describes the front panel function and operation of each SLM-series DC load module. Refer to the SLM mainframe operation manual for descriptions of the memory Store/Recall and of GPIB and RS-232 remote programming.

3.1 Front Panel Controls and Indicators

3.1.1 Description

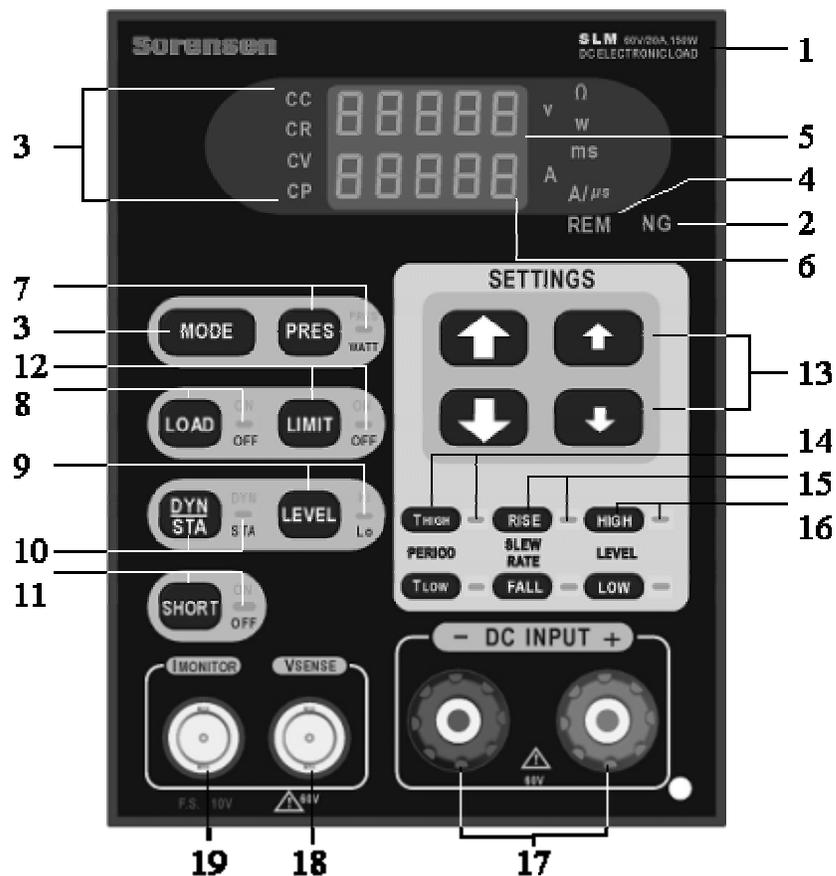

Figure 3-1 SLM-Series DC Plug-in Module Front Panel

1 Module Label

Shows the load model name and its maximum ratings.

2 NG LED

Lights to indicate "No Go" (fail) when Vmeter, Ameter, or Wattmeter exceeds the upper or lower limit set. Off, not lit, indicates "Go" (no fail).

3 CC, CR, CV, CP LEDs and MODE Key

- LEDs indicate which mode is in operation:
 - CC = Constant Current
 - CR = Constant Resistance
 - CV = Constant Voltage
 - CP = Constant Power
- The MODE key switches from one mode to the next.

4 REM LED

Indicates remote operation:

- When lit, the unit is under remote control and cannot be operated through the front panel keys. (Remote controller releases control by GPIB command).
- When off, the unit is under local control and can be manually operated using the front panel keys.

5 Upper 5-Character Digital Meter (DM) and Associated LEDs

The DM is for multi-purpose display, depending on selected mode:

- In PRESet OFF mode, displays voltage of DC input terminal or VSENSE BNC input.
- In PRESet ON mode, displays values being programmed for CV, CR, or CP (value for CC is displayed in lower DM).
- In WATT On mode, displays load Watt meter.
- In LIMIT ON mode:
 - displays GO/NG upper limit values for voltage, current, and power
 - displays SENSE to indicate VSENSE control
 - displays voltage settings for LOAD ON or for LOAD OFF

Associated LEDs indicate the displayed value's unit:

- V = Value displayed is in Volts
- A = Value displayed is in Amps
- Ω = Value displayed is in Ohms
- W = Value displayed is in Watts
- ms = Value displayed is in milliseconds
- A/ μ s (or mA/ μ s) = Value displayed is in Amps per microsecond (or milliamps per microsecond)

6 Lower 5-Character Digital Meter (DM) and Associated LEDs

Multi-purpose display, depending on selected mode:

- In PRESet OFF mode, displays:
 - actual load current when SHORT status is OFF
 - short circuit current when SHORT status is ON
- In PRESet ON mode, displays values being programmed for:
 - CC
 - THIGH/TLOW when in Dynamic mode
 - RISE/FALL slew rates when in Dynamic mode
- In LIMIT ON mode, displays:
 - oVP (over voltage), oCP (over current), oPP (over power), or oTP (over temperature) when in protection mode
 - GO/NG low limit values for voltage, current, and power
 - Auto or On setting for VSENSE control
 - either Ld-on or Ld-off to indicate whether Load voltage setting mode is On or Off

Associated LEDs indicate the displayed value's unit:

- V = Value displayed is in Volts
- A = Value displayed is in Amps
- Ω = Value displayed is in Ohms
- W = Value displayed is in Watts
- ms = Value displayed is in milliseconds
- $A/\mu s$ (or $mA/\mu s$) = Value displayed is in Amps per microsecond (or milliamps per microsecond)

7 PRES Key and ON/WATT LED

- PRES key sequentially selects Preset ON, Watt ON and Preset OFF
- LEDs indicate which is selected at any given time:
 - Preset On = LED is lit amber
 - Watt On = LED is lit green
 - Preset Off = LED is not lit

8 LOAD Key and ON/OFF LED

- LOAD key toggles ON/OFF the DC load. (Does not affect the programmed settings).
- LED indicates the status of the Load function:
 - LED lit indicates the Load function is ON and ready to sink current from the DC input.
 - LED not lit indicates the Load function is OFF.

9 LEVEL Key and Hi/Lo LED

- LEVEL key toggles between the High or Low levels for programming the high and low level load values for CC, CR, CV, CP when in those modes. (See Key **16** for setting the Level values. (These High/Low level load values can be programmed while in Static mode but not in Dynamic mode. See Key **10**, DYN/STA, next).
- LED indicates whether the Load value being programmed is High level or Low level:
 - LED lit = high (HI) level
 - LED not lit = low (Lo) level

Section 3.2.3 provides guidelines for programming the values.

10 DYN / STA Key and LED

- DYN/STA key toggles between Dynamic and Static modes only when in Constant Current mode or Constant Power mode. (When in Constant Resistance and Constant Voltage modes, the SLM-series DC load module automatically adjusts to Static mode because Dynamic mode is not available for either).
- LED indicates whether the SLM-series DC load module is in Dynamic or Static mode:
 - LED lit = Dynamic
 - LED not lit = Static

11 SHORT Key and ON/OFF LED

- The SHORT key toggles the short circuit of DC input terminal On and Off.
- LED indicates the ON/OFF status of the short circuit
 - LED lit = ON
 - LED not lit = OFF

12 LIMIT Key and LED

- The Limit key sequentially selects the following parameters to program their settings:
 - OFF
 - GO/NG Upper/Lower Voltage limit
 - GO/NG Upper/Lower Current limit
 - GO/NG Upper/Lower Power limit
 - Vsense Auto/ON
 - Load ON voltage
 - Load OFF voltage
 - Range: Auto/Rangell
 - iStart
 - iStop
 - iStep
 - Pstart
 - Pstop
 - Pstep
 - V threshold

- Test Mode: Normal, OCP, OPP
- returns to OFF and the loop repeats
- The LED indicates whether limits are being programmed or not:
 - LED lit = Limit programming ON
 - LED not lit = Limit programming OFF

13 Coarse/Fine, Increment/Decrement (inc/dec) Keys

These keys are used in two different ways, depending on whether one or both 5-character DMs are displaying a value:

- When only one value is displayed, such as for setting Load On voltage, these keys increase or decrease the value as follows:
 - The larger arrows, \uparrow \downarrow , make coarse (large) adjustments to the displayed value.
 - The smaller arrows, $\uparrow\downarrow$, make fine (small) adjustments to the displayed value.
- When two values are displayed (one in upper 5-digit display and one in lower 5-digit display), such as for setting upper and lower limits, these keys increase or decrease the values as follows:
 - The larger arrows, \uparrow \downarrow , increase or decrease the value in the upper 5-digit display.
 - The smaller arrows, $\uparrow\downarrow$, increase or decrease the value in the lower 5-digit display.

14 THIGH / TLOW PERIOD Keys and LEDs

- The THIGH and TLOW keys are used to program the duration of high and low load current levels, respectively.
- The LEDs indicate which time period (THIGH or TLOW) is being programmed.

15 RISE / FALL SLEW RATE Keys and LEDs

- The Rise and Fall keys are used to program the speed of load current changes from low level to high level (Rise) and from high level to low level (Fall).
- The LEDs indicate which slew rate (Rise or Fall) is being programmed.

16 HIGH / LOW LEVEL Keys and LEDs

- These two keys are used to program the High and Low loads for current, resistance, voltage, or power, depending on which mode is set (CC, CR, CV, or CP). (Follow guidelines in the Operation-Setup section that follows).
- The LEDs indicate which level (HIGH or LOW) is being programmed.

17 -/+ DC INPUT Binding Posts

The negative (left) and positive (right) terminal of load input connector

- +: Connect to the positive and ground output for a positive output power supply
- -: Connect to the negative and ground output for a negative output power supply.

NOTE: Before testing, ensure that the voltage and current do not to exceed the maximum

rating of each SLM-series DC load module and the connection method utilized (see Section 2.2.1).

Also check the polarity of DC input connection before testing.

18 VSENSE

Measures the specific voltage points through the V-sense BNC - CLIP cable.

NOTE: Avoid High Voltage Hazards - refer to Section 2.2.2 for cautions and warnings about connections.

19 IMONITOR

Sends the load current waveform output to an oscilloscope to evaluate the current waveform of a power supply under test.

See Section 1 for voltage/current relationship of I-Monitor outputs in SLM-series DC series modules.

3.1.2 Summary Chart

The front panel controls are summarized in Figure 3-2.

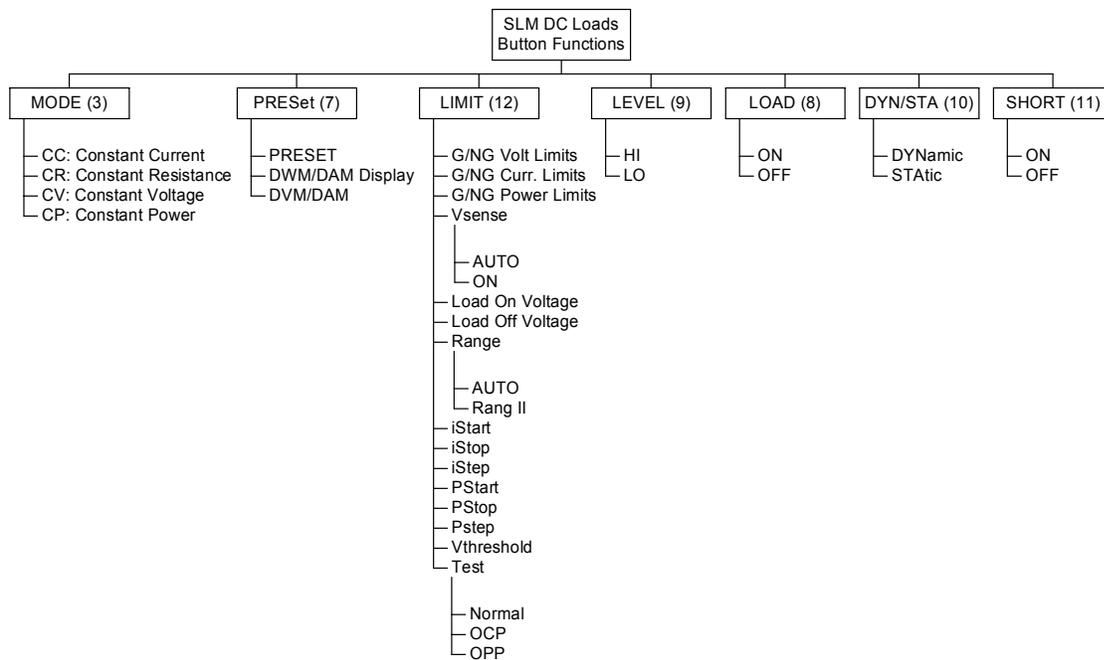

Figure 3-2 Organization of Front Panel Controls of SLM-Series DC Plug-in Module

3.2 Operation – Setup and OCP/OPP Tests

The SLM series DC loads have six operating modes: Constant Current (CC), Constant Voltage (CV), Constant Power (CP), Constant Resistance (CR), all selected with the MODE key, Shorts mode, selected with the SHORT key, and Dynamic mode, selected with the DYN/STA key. (Dynamic mode allows controlled current transitions between two states in CC or CP modes only).

Note: For the remainder of this Section, the bolded number within parentheses following a front panel key name, refers to the labels in Figure 3-1.

3.2.1 Overview of Front Panel Operation

Limits must be set up before selecting a mode in which to operate. The LIMIT key (**12**) is used to set the Go/No Go upper and lower limits for voltage, for current and for power. It is also used to set the system configuration for V-sense control, for Load ON voltage and for Load OFF voltage.

After setting up the initial LIMIT parameters (see Section 3.2.2), use the MODE key (**3**) to enter CC, CR, CV, or CP mode and set up the applicable parameters in each mode. Use the HIGH and LOW keys (**16**) to set the load level values for each mode. If programming values in Dynamic (**10**) mode (again, for CC and CP modes only), the THIGH, TLOW (**14**), and RISE, FALL (**15**) values must also be set.

Then, select the high or low programmed Load level by pressing the LEVEL key (**9**), and last, press the LOAD key (**8**) to apply load to the input terminals.

3.2.2 Initial Setup (LIMIT Key)

Pass / Fail Limits, Go/No GO Limits

If pass/fail limits are not desired, skip this step. This step is to set the upper and lower limit values within which the inputs must fall in order to pass the test. (Pass is indicated when the NG register is set to 0 and the NG LED (**2**) remains not lit). If the inputs fall outside those values, i.e., they are less than the lower limit value or higher than the upper limit value, the test is a “fail” or No Go. (Fail is indicated when the NG register is set to 1 and the NG LED is lit).

Voltage: Press the LIMIT key until its corresponding ON LED (**12**) is lit and the “V” LED (**5**) is lit. The upper 5-digit display shows the upper voltage limit; the lower 5-digit display shows the lower voltage limit. Use the larger \uparrow \downarrow increment/decrement arrows to set the upper limit and the smaller \uparrow \downarrow increment/decrement arrows to set the lower limit.

Current: Press the LIMIT key until its corresponding ON LED is lit and the “A” LED (**5**) is lit. The upper 5-digit display shows the upper current limit; the lower 5-digit display shows the lower current limit. Use the larger \uparrow \downarrow increment/decrement arrows to set the upper limit and the smaller \uparrow \downarrow increment/decrement arrows to set the lower limit.

Power: Press the LIMIT key until its corresponding ON LED is lit and the “W” LED (**5**) is lit. The upper 5-digit display shows the upper power limit; the lower 5-digit display shows the lower power limit. Use the larger \uparrow \downarrow increment/decrement arrows to set the upper limit and the smaller \uparrow \downarrow increment/decrement arrows to set the lower limit

VSENSE: Press the LIMIT key until SEnSE appears on the display. Use any of the arrow keys to toggle between AUTO or ON.

- In AUTO, if the external VSENSE voltage (through the BNC connection) is greater than 1V for SLM-series DC 60V modules or 3V for 250, 500V modules; the voltage displayed on the 5-digit DVM is from the VSENSE input. Otherwise, when the voltage on the BNC is equal to or less than the minimum voltage, the 5-digit DVM measures the DC input terminals of the load module.
- In VSENSE ON mode, the 5-digit voltage meter displays the voltage of VSENSE BNC input.

LOAD ON: Press the LIMIT key until Ld-on appears on the lower 5-digit DM display. Use the coarse/fine adjust keys to set the LOAD ON voltage, which is displayed on the upper 5-digit DM. The LOAD ON voltage must be higher than the LOAD OFF voltage. (If the LOAD ON voltage is set lower than the LOAD OFF voltage, the load will reset the LOAD ON voltage equal to the LOAD OFF voltage).

LOAD OFF: Press the LIMIT key until LdoFF appears on the lower 5-digit DM display. Use the coarse/fine adjust keys to set the LOAD OFF voltage, which is displayed on the upper 5-digit DM. The LOAD OFF voltage must be lower than the LOAD ON voltage. (If the LOAD OFF voltage is set higher than the LOAD ON voltage, the load will reset the LOAD OFF voltage equal to the LOAD ON voltage).

Range Auto/Fixed Range II: There are two programming ranges in Constant Current and Constant Resistance modes. Range selection can be automatic or fixed in Range II, as set by the LIMIT key. Ranges are described in the following examples:

Constant Current mode: (SLM-60-60-300 example)

Range I (6A) indicates low load current operating range; Range II (60A) indicates high load current operating range. The detailed specifications of load current range are listed in Table 1-1. The current range automatically changes according to the programmed load current. Range I is selected automatically if the programmed load current is less than the maximum current of Range I (6A), and will set to Range II automatically when the programmed current is higher than the maximum current of Range I (6A).

Constant Resistance mode:

Range I indicates low load resistance operating range (high resistance, low current), Range II indicates high load resistance operating range (low resistance, high current). The detailed resistance range specifications are shown in Table 1-1. The resistance range automatically changes according to the programmed load resistance.

The SLM-series electronic load will set Range I automatically if the programmed load resistance is higher than the minimum load resistance of Range I, and will set to Range II when the programmed load resistance is lower than the minimum load resistance of Range I.

The normal operating mode for programming values is for the load to automatically select low or high range (CC or CR modes only). However, in the use of the analog input, the load can be programmed in Range II at all times.

Press the LIMIT key until rAnGE appears on the upper 5-digit display. Use the inc/dec arrows to set AUTO or rAn2. rAn2 forces the load to Range II for CC and CR mode, as defined in Table 3-2.

Over Current Test (OCP Test)

An OCP test automatically steps the current from a start current (iStAr) to a stop current (iStOP) in equal increments (iStEP). When the voltage falls below a threshold voltage (Uth), the test stops and the current setting is saved.

The LIMIT key steps through each of the first three setup parameters. The threshold voltage setting appears after the OPP test parameters.

After setting the four parameters (start, stop, step and threshold), refer to Test Mode instructions to set the OCP test mode, store and run the test.

Over Power Test (OPP Test)

An OPP test automatically steps the current from a start power (PStAr) to stop power (PStOP) in equal increments (PStEP). When the voltage falls below a threshold voltage (Uth), the test stops and the power setting is saved.

Each press of the LIMIT key steps through settings for the four setup parameters.

After setting the four parameters, set the OPP test mode, store and run the test.

Test Mode

Test modes are Normal, OCP and OPP. All modes except OCP and OPP are “normal” mode.

Press the LIMIT key until tEst appears on the display. Use the inc/dec arrows to set Normal, OCP or OPP modes.

If OCP or OPP mode is selected, store the setting in the chassis memory as described in the SLM-4 or SLM-1 programming manuals.

To run an OCP or OPP test, perform a recall operation where the test was saved (see SLM-1 or SLM-4 manual).

To return to Normal mode, press the LIMIT key until tEst appears on the display. Use the down arrows until “nor” appears on the display.

Please see Figure 3-3 for flowchart.

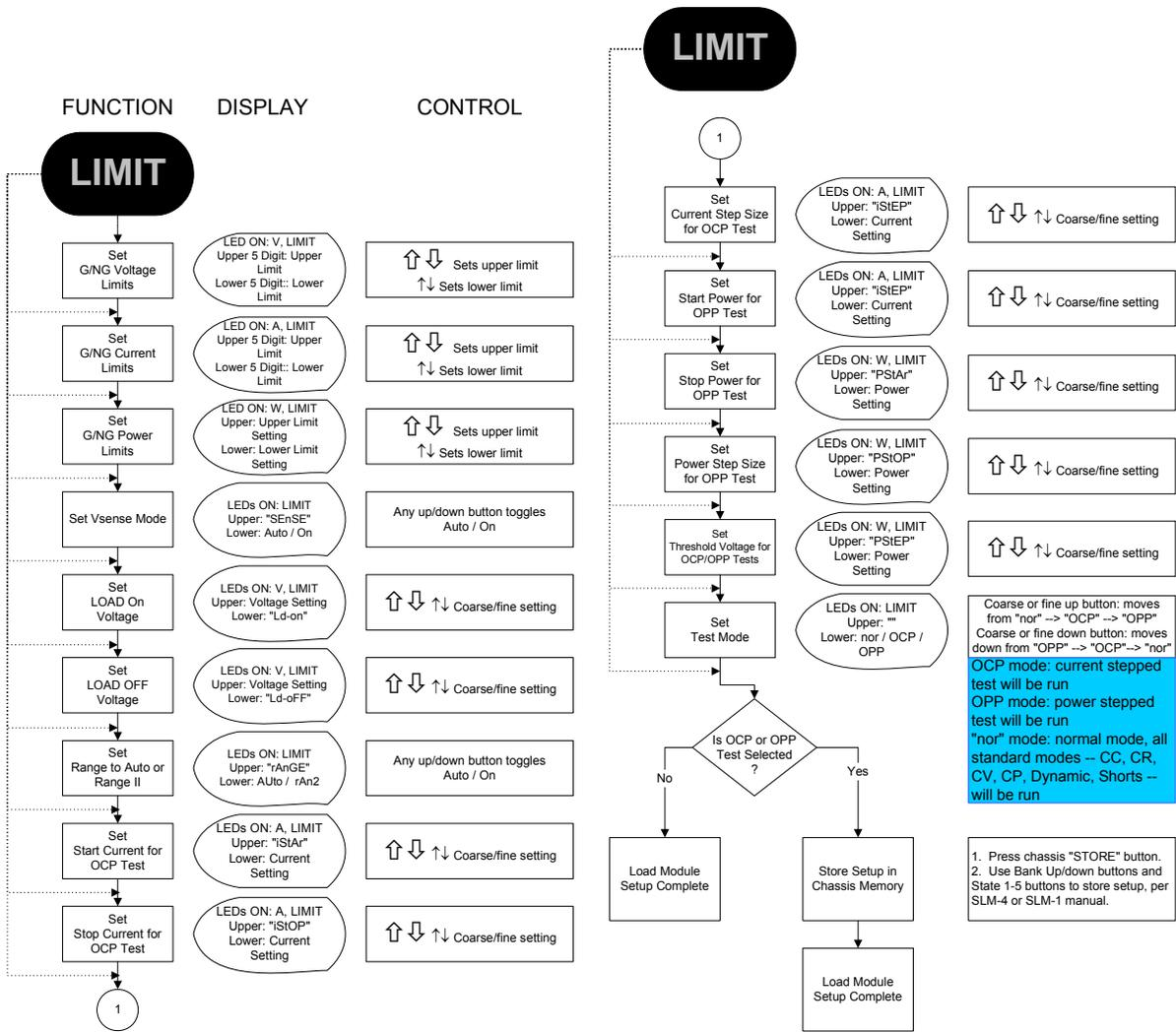

Figure 3-3 Flowchart for Load Module General Setup Parameters and OCP and OPP Tests

Press the LIMIT button to enter setup mode. To skip setup of any parameter, scroll past by pressing the LIMIT key to advance to the next parameter. When setup is complete, press LIMIT key until its LED is no longer lit.

(.....▶ indicates pressing LIMIT button to advance to next parameter).

3.2.3 Normal Operating Modes

In the following instructions, the numbers within parentheses refer to the front panel components of the SLM-series DC plug-in-module, as labeled in Figure 3-1.

CC Mode

CC mode can be either static (fixed DC level) or dynamic (two levels with timing and slew rates programmed). Dynamic mode is described later in this Section 3.2.3. In static mode, two levels can be set to allow for quick switching between two current levels.

1. Press the MODE key **(3)**, until the CC LED **(3)** is lit.
2. Press the PRES key **(7)** to view the programmed values. The high level must be higher than the low level; the load will not allow the HIGH level to be lower than the LOW level.
 - a. To set the high level, press the HIGH key **(16)**. Use the inc/dec arrows to set the desired level.
 - b. To set the low level, press the LOW key **(16)**. Use the inc/dec arrows to set the desired level.
3. To exit the Preset mode, press the PRES key until its LED is green (power/watts displayed) or not lit (volts displayed).
4. Press the LEVEL key to select the desired level CC mode by. When the LEVEL LED is lit, the HIGH level is selected and when not lit, the LOW level is selected.
5. Press the LOAD key **(8)** to toggle the load off or on. Press the LEVEL key at any time to switch between the HIGH and LOW level settings. The value for current can be changed at any time using the inc/dec arrows. The values set can be viewed by pressing the PRES key.

CR Mode

CR mode static (fixed DC level) can be set in two levels to allow for quick switching between two resistance levels. High and low levels are referenced to the resulting current level, thus the $\hat{\uparrow}\hat{\uparrow}$ keys will decrease the resistance setting and the $\hat{\downarrow}\hat{\downarrow}$ keys will increase the resistance setting.

1. Press the MODE **(3)** key, until the CR LED is lit **(3)**.
2. Press the PRES key **(7)** to view the programmed values. The HIGH level must be set to a lower resistance than the LOW level; the load will not allow the HIGH level to be higher than the LOW level.
 - a. To set the high level, press the HIGH key **(16)**. Use the inc/dec arrows to set the desired level.
 - b. To set the low level, press the LOW key **(16)**. Use the inc/dec arrows to set the desired level.
3. To exit the Preset mode, press the PRES key until its LED is green (power/watts displayed) or not lit (volts displayed).

4. Press the LEVEL key **(9)** to select the desired CR level. When the LEVEL LED is lit, the HIGH level (lower resistance) is selected and when not lit, the LOW level is selected (higher resistance).
5. Press the LOAD key **(8)** to toggle the load off or on. Press the LEVEL key **(9)** at any time to switch between the settings. The current can be changed at any time using the inc/dec arrows. The value set can be viewed by pressing the PRES key.

CV Mode

CV mode operates in static mode only.

1. Press the MODE key **(3)** until the CV LED **(3)** is lit.
2. Press the PRES key **(7)** to view the programmed values. The high level must be higher than the low level; in setting the values, the load will not allow the HIGH level to be lower than the LOW level.
 - a. To set the high level, press the HIGH key **(16)**. Use the inc/dec arrows to set the desired level.
 - b. To set the low level, press the LOW key **(16)**. Use the inc/dec arrows to set the desired level.
3. To exit the Preset mode, press the PRES key **(7)** until its LED is green (power/watts displayed) or not lit (volts displayed).
4. Press the LEVEL key **(9)** to select the desired level CV mode. When the LED is lit, the high level is selected; when the LED is not lit, low level is selected.
5. Press the LOAD key **(8)** to toggle the load off or on. Press the LEVEL key **(9)** at any time to switch between the settings. The current can be changed at any time using the inc/dec arrows. The value set can be viewed by pressing the PRES key.

CP Mode

CP mode can be either static (fixed DC level) or dynamic (two levels with timing and current slew rates programmed). Dynamic mode is described next. In static mode, two levels can be set to allow for quick switching between two current levels.

1. Press the MODE key **(3)**, until the CP LED **(3)** is lit.
2. Press the PRES key **(7)** to view the programmed values. The high level must be higher than the low level; in setting the values below, the load will not allow the HIGH level to be lower than the LOW level.
 - a. To set the high level, press the HIGH key **(16)**. Use the inc/dec arrows to set the desired level.
 - b. To set the low level, press the LOW key **(16)**. Use the inc/dec arrows to set the desired level.
3. To exit the Preset mode, press the PRES key **(7)** until its LED is green (power/watts displayed) or not lit (volts displayed).

4. Press the LEVEL (9) key to select the desired level CP mode. When the LED is lit, the high level is selected; when the LED is not lit, low level is selected.
5. Press the LOAD (8) key to toggle the load off or on. Press the LEVEL key at any time to switch between the high and low settings. The power can be changed using the inc/dec arrows. The value set can be viewed by pressing the PRES key (7) until the amber LED is lit.

Dynamic Mode

Dynamic mode allows fast state switching in either current or power mode. It controls the dwell time and current slew rate, as well as the high and low values.

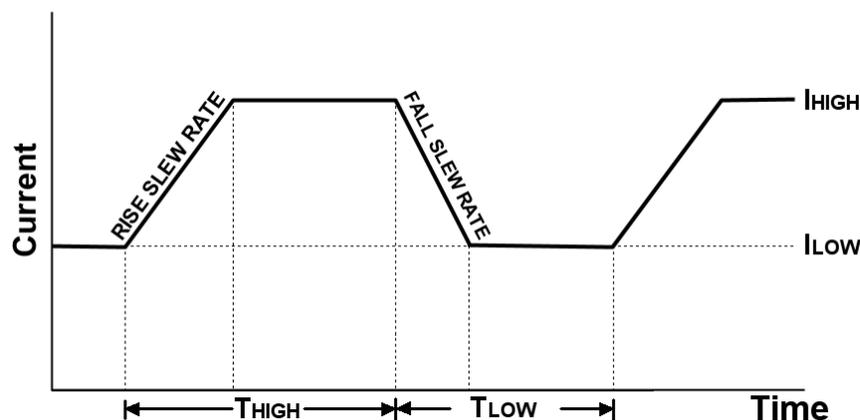

Figure 3-4 Dynamic Mode Waveform and Definition Parameters

1. Press the MODE key (3), until the desired mode LED (3) is lit, CP or CC only.
2. Set high and low values:
 - a. Press the PRES key (7) until its amber LED is lit and the programmed values are displayed. The high level must be higher than the low level; in setting the values below, the load will not allow the HIGH level to be lower than the LOW level.
 - b. To set the high LEVEL, press the HIGH key (16). Use the inc/dec arrows to set the desired level.
 - c. To set the low LEVEL, press the LOW key (16). Use the inc/dec arrows to set the desired level.
3. Set the current RISE and FALL slew rates:
 - a. Press the RISE key (15). Use the inc/dec arrows to set the desired RISE rate.
Note: In CP mode, the rise rate is limited to Range 1.
 - b. Press the FALL key (15). Use the inc/dec arrows to set the desired FALL rate.
Note: In CP mode, the rise rate is limited to Range 1.
4. Set the dwell time (PERIOD):
 - a. Press the THIGH key (14). Use the inc/dec arrows to set the desired high state time.
 - b. Press the TLOW key (14). Use the inc/dec arrows to set the desired low state time.

5. Operating in Dynamic Mode:
 - a. Press the MODE key (**3**), until the desired mode LED (**3**) is lit, CP or CC only.
 - b. Press the DYN/STA key (**10**) until its amber LED is lit.
 - c. Press the LOAD key (**8**) to turn the load on (amber LED is lit).

Shorts Mode

Shorts mode puts the load in minimum resistance/maximum current state.

1. To turn on shorts mode, press the SHORT key (**11**) until its LED is lit. This overrides any selection made with the MODE key. When the LOAD key is toggled to ON, the load simulates a short by sinking maximum rated current at minimum resistance.
2. To exit shorts mode, press the SHORT key (**11**) until its LED is not lit.

Normal Operating Mode Flowchart

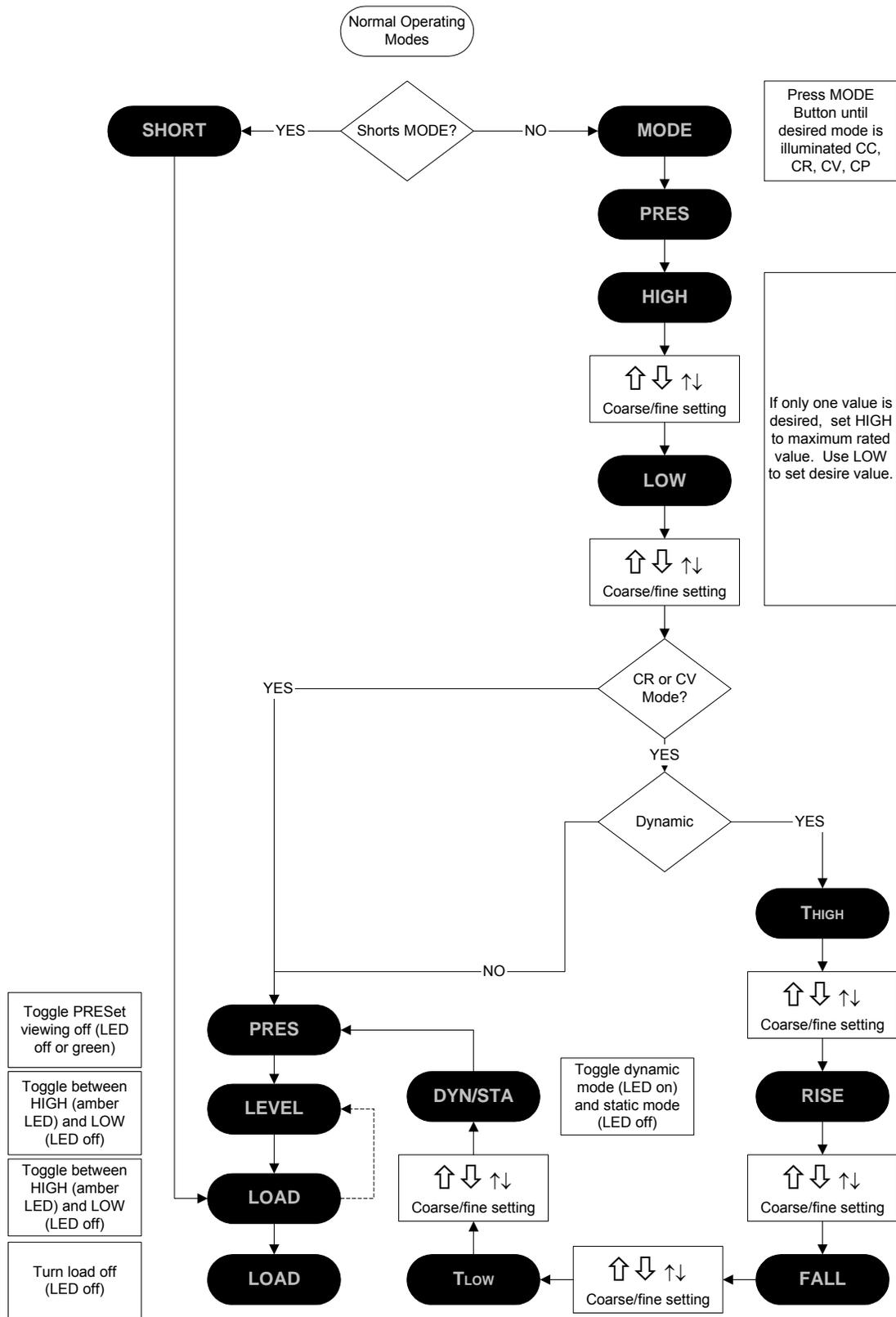

Figure 3-5 Normal Operating Mode Flowchart

3.2.4 Initial Setting of SLM-Series DC Load Modules

Table 3-1 lists the factory, or initial, load value settings of the SLM-series DC electronic load when it is initially powered ON once it first arrives from the factory.

Item	SLM-60-15-75	SLM-60-30-150	SLM-60-60-300	SLM-250-10-300	SLM-500-10-300
Basic Settings					
CC LOW [amps]	0.0000	0.0000	0.000	0.0000	0.0000
CC HIGH [amps]	0.0000	0.0000	0.000	0.0000	0.0000
CR HIGH [Ω]	15000.	7500.	3750.	18750.	18750.
CR LOW [Ω]	15000.	7500.	3750.	18750.	18750.
CV HIGH [volts]	60.00	60.00	00.00	250.0	500.0
CV LOW [volts]	60.00	60.00	60.00	250.0	500.0
CP LOW [watts]	0.000	0.000	0.000	0.000	0.000
CP HIGH [watts]	0.000	0.000	0.000	0.000	0.000
Dynamic Settings					
FALL [A/ μ s]	0.0625	0.1250	0.2500	0.0500	0.0250
RISE [A/ μ s]	0.0625	0.1250	0.2500	0.0500	0.0250
THIGH [ms]	0.0500	0.0500	0.0500	0.0500	0.0500
TLOW [ms]	0.0500	0.0500	0.0500	0.0500	0.0500
Go/No Go Limits					
V HIGH	60.00	60.00	60.00	300.0	600.0
V LOW	0.000	0.000	0.000	0.000	0.000
CURR. HIGH	15.000	30.00	60.00	12.000	6.000
CURRENT LOW	0.000	0.000	0.000	0.000	0.000
POWER HIGH	75.00	150.0	300.0	300.0	200.0
POWER LOW	0.000	0.000	0.000	0.000	0.000
System Settings					
V SENSE	Auto	Auto	Auto	Auto	Auto
LD-ON [volts]	1.000	1.000	1.000	2.000	4.000
LD-OFF [volts]	0.5	0.5	0.5	0.150	0.300

Table 3-1 SLM-Series DC Electronic Load Factory Settings for Power On

3.2.5 Analog Programming Input

The Electronic Load has an analog programming 9-pin input on the rear panel of SLM mainframe, labeled CH1, CH2, CH3, and CH4 respectively. See the SLM Mainframe Operations Manual for connection instructions. CC and CP modes can be programmed with a 0 to 10V analog signal (arbitrary waveform or arbitrary waveform + dc) connected to the analog programming input.

Example: SLM-60-60-300. The 0 to 10V Analog signal can program the 0 to full-scale input range in the CC mode (0 to 6A range when load current setting is less than 6A, or 0 to 60A range when load current setting is higher than 6A) or in the CP mode (0 to 300W). To be operated only in the high range (Range II).

The analog programming signal can act alone or it can be summed with the programmed

value via GPIB, RS-232, or the front panel. Figure 3-6 shows the analog programming signal (4 Vac, 500Hz) summed with the 24A programmed setting in CC mode.

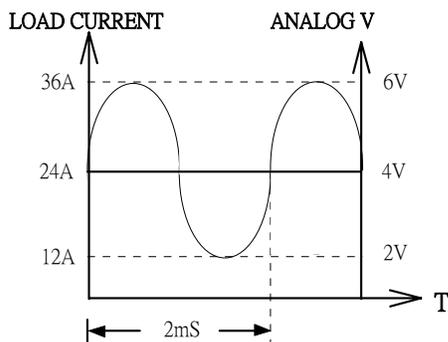

Figure 3-6 Analog Programming Load Current in CC Mode Operation



Caution: The analog input is always active. Even if the load is in the “OFF” state at the front panel or through remote control, the load will draw current when voltage is applied to the analog input.

3.2.6 Load Coarse/Fine Increase/Decrease Adjustment Key

The load current step change or resolution is shown in Table 3-2 for each load module.

Pressing and holding any one of the four arrow keys for more than 1 second speeds the step change; either release the arrow key to stop at a value, or wait for the adjustment to reach the maximum or minimum load current setting.

SLM-60-15-75	RANGE I		RANGE II	
COARSE/FINE LOAD CURRENT ADJUSTMENT KEY	↑ ↓	↓ ↑	↑ ↓	↓ ↑
CC Mode	4.0 mA	0.4 mA	40.0 mA	4.0 mA
CR Mode	6.666mS	0.0666mS	0.1066Ω	1.066mΩ
CV Mode	0.16V	16mV	0.16V	16mV
CP Mode	0.2W	0.02W	0.2W	0.02W

SLM-60-30-150	RANGE I		RANGE II	
COARSE/FINE LOAD CURRENT ADJUSTMENT KEY	↑ ↓	↓ ↑	↑ ↓	↓ ↑
CC Mode	8.0 mA	0.8 mA	80 mA	8.0 mA
CR Mode	13.33mS	0.133mS	53.33mΩ	0.533mΩ
CV Mode	0.16V	0.016V	0.16V	0.016V
CP Mode	0.4W	0.04W	0.4W	0.04W

(Continued)

SLM-60-60-300	RANGE I		RANGE II	
COARSE/FINE LOAD CURRENT ADJUSTMENT KEY	↑ ↓	↓↑	↑ ↓	↓↑
CC Mode	16.0 mA	1.6 mA	160 mA	16 mA
CR Mode	26.66mS	0.266mS	26.66mΩ	0.266mΩ
CV Mode	0.16V	0.016V	0.16V	0.016V
CP Mode	0.8W	0.08W	0.8W	0.08W

SLM-250-10-300	RANGE I		RANGE II	
COARSE/FINE LOAD CURRENT ADJUSTMENT KEY	↑ ↓	↓↑	↑ ↓	↓↑
CC Mode	2.68 mA	0.268 mA	26.8 mA	2.68 mA
CR Mode	1.067mS	0.0107mS	0.667Ω	6.67mΩ
CV Mode	666.7mV	66.67mV	666.7V	66.67mV
CP Mode	0.8W	0.08W	0.8W	0.08W

SLM-500-10-300	RANGE I		RANGE II	
COARSE/FINE LOAD CURRENT ADJUSTMENT KEY	↑ ↓	↓↑	↑ ↓	↓↑
CC Mode	2.68 mA	0.268 mA	26.8 mA	2.68 mA
CR Mode	0.053mS	0.0053mS	133.3Ω	13.33mΩ
CV Mode	1.333V	133.3mV	1.333V	133.3mV
CP Mode	0.8W	0.08W	0.8W	0.08W

Table 3-2 Resolution of Range I/II vs Coarse/Fine Load Current Setting Keys

3.2.7 I-Monitor

The I-Monitor BNC monitors the Electronic load's input current or short current. An isolated amplifier output 0V to 10V full-scale signal indicates the zero to full-scale current for each Electronic load module.

The isolated voltage is 250V between load module and I-Monitor BNC output, and it has the same ground potential with mainframe (i.e., GPIB ground potential).

The isolated I-Monitor feature eliminates the grounding problem while connecting I-Monitor BNC and measuring power supply output voltage to oscilloscope simultaneously, because dual oscilloscope channels are not isolated.

This feature is also useful in testing multiple output power supplies that have simultaneous positive and negative polarity output, because the I-Monitor output is isolated from each load module or each power supply output. It eliminates grounding problems while monitoring the current signal from the I-Monitor BNC connector.

3.2.8 Protection Features



CAUTION: Never apply the AC line voltage or input voltage in excess of the rated voltage, to the input terminals. It may cause damage to the electronic load module.

There are five protection functions for the SLM-Series DC electronic load: over-voltage, over-current, over-power, over-temperature and reverse polarity. When an electronic load exceeds the normal work area range, one of the above protection functions activates and switches the load off. The 5-digit display flashes which condition notifies the user of the protection status.

- If the any of the protection circuits is tripped, the electronic load immediately shuts down to protect against the abnormal condition.
- The SLM-series DC electronic load automatically resets the Over voltage, Over current, Overpower and Over temperature protection once the input returns to below maximum rating and the "LOAD" key is pressed to the "ON" state.

Over voltage

- The protection point of over voltage protection (OVP) is preset in the load. The activation values are shown in Table 3-3.
- When an over-voltage condition occurs, the upper 5-digit monitor on the front panel of the electronic load flashes "oVP". The load automatically goes to a LOAD OFF state.
- Normal operation may be resumed once the input falls below maximum rating.



WARNING: The OVP circuit does not protect against severe over voltage conditions. Voltages above 60V, 400V and 900V applied across the input terminals of 60V-rated, 250V-rated and 500V-rated loads, respectively, will permanently damage the electronic load. This damage will require factory repair.

Over Current (OCP)

- The protection point of over current protection (OCP) is preset in the load. The activation values of the OCP circuit are shown in Table 3-3.
- When an over-current condition occurs, the lower 5-digit monitor on the front panel of the electronic load flashes "oCP". The load automatically goes to a LOAD OFF state.
- Normal operation may be resumed once the input falls below maximum rating.

Over Power (OPP)

- The protection point of over power protection (OPP) is preset in the load. The activation values of the OPP circuit are shown in Table 3-3.
- When an over-power condition occurs, the upper 5-digit monitor on the front panel flashes "oPP". The load automatically goes to a LOAD OFF state.
- Normal operation may be resumed once the input falls below maximum rating.

Over Temperature (OTP)

- SLM-Series DC electronic loads are equipped with a temperature sensor(s). When any module's heat sink rises to a temperature greater than 85°C, the OTP circuit trips. The lower 5-digit monitor on the front panel flashes "otP". The load will automatically go to a LOAD OFF state.
- Once in OTP condition, please check environmental condition such as the ambient temperature and the distance between the Electronic load mainframe's rear panel and wall, which should be greater than 6in. / 15cm.
- Normal operation may be resumed once the temperature falls below maximum.

Reverse Polarity

- The SLM-series DC electronic load conducts reverse current when the polarity of the DC source connection is incorrect. The maximum reverse current is the same as the maximum forward current.



WARNING: If the reverse current exceeds the current rating, it may cause damage to the SLM-Series DC electronic Load.

- When reverse polarity occurs, the reverse current value (negative reading) is displayed on the 5-digit monitor on the front panel; turn OFF power to the DC source and make the correct connections.

Model	OVP	OCP	OPP	OTP
SLM-60-15-75	63V	15.75A	79W	85°C
SLM-60-30-150	63V	31.5A	158W	85°C
SLM-60-60-300	63V	63A	315W	85°C
SLM-250-10-300	263V	10.5A	315W	85°C
SLM-500-10-300	525V	10.5A	315W	85°C

Table 3-3 Summary of Over Protection Values

SECTION 4 APPLICATIONS

This chapter describes the application information for SLM-series DC electronic load module.

4.1 Local Sense Connections

Figure 4-1 illustrates a typical connection of the electronic load to the DC power supply. Local sensing is used in applications where lead lengths are relatively short, or where load regulation is not critical. The 5-digit voltage meter of the SLM-series DC electronic load measures the voltage of the DC INPUT terminal automatically. Load leads should be bundled or tie-wrapped together to minimize inductance.

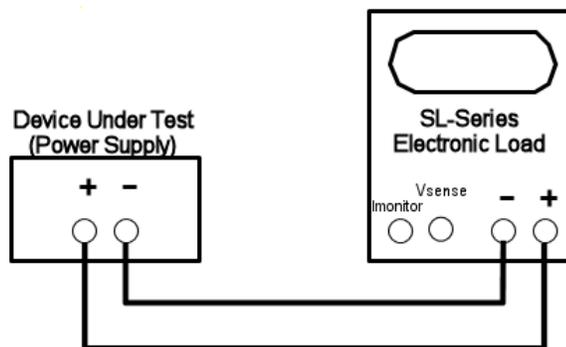

Figure 4-1 Local Voltage Sense Connections

4.2 Remote Sense Connections

Figure 4-2 illustrates a typical set up with the electronic load connected for remote sense operation. The remote V-sense BNC cable of the electronic load is connected to the power supply output. Remote sensing compensates for the voltage drop in applications that require long lead lengths. The 5-digit voltage Meter of SLM-series DC electronic load measures the voltage of V-sense BNC input terminal automatically, so the high accuracy 5-digit voltage meter can measure at the power supply output. Load leads should be bundled or tie wrapped together to minimize inductance.

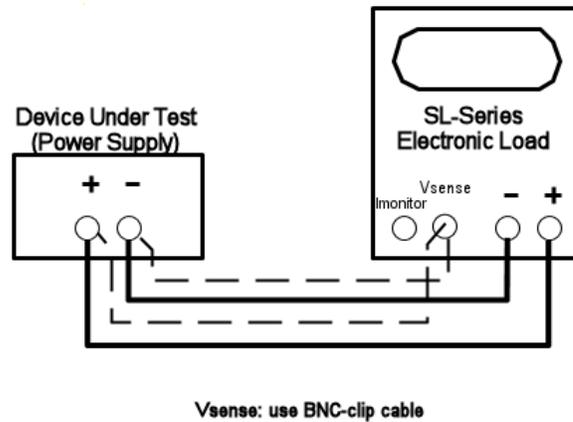

Figure 4-2 Remote Voltage Sense Connections

4.3 Constant Current (CC) Mode Application

The Constant Current mode is very suitable for testing Load Regulation, Cross Regulation, Output Voltage and Dynamic Regulation of the power supply, and for testing the discharge characteristics and the lifetime of a battery.

4.3.1 Static Mode:

Major application (see Figure 4-3):

- Voltage source testing.
- Power supply load regulation testing
- Battery discharge testing

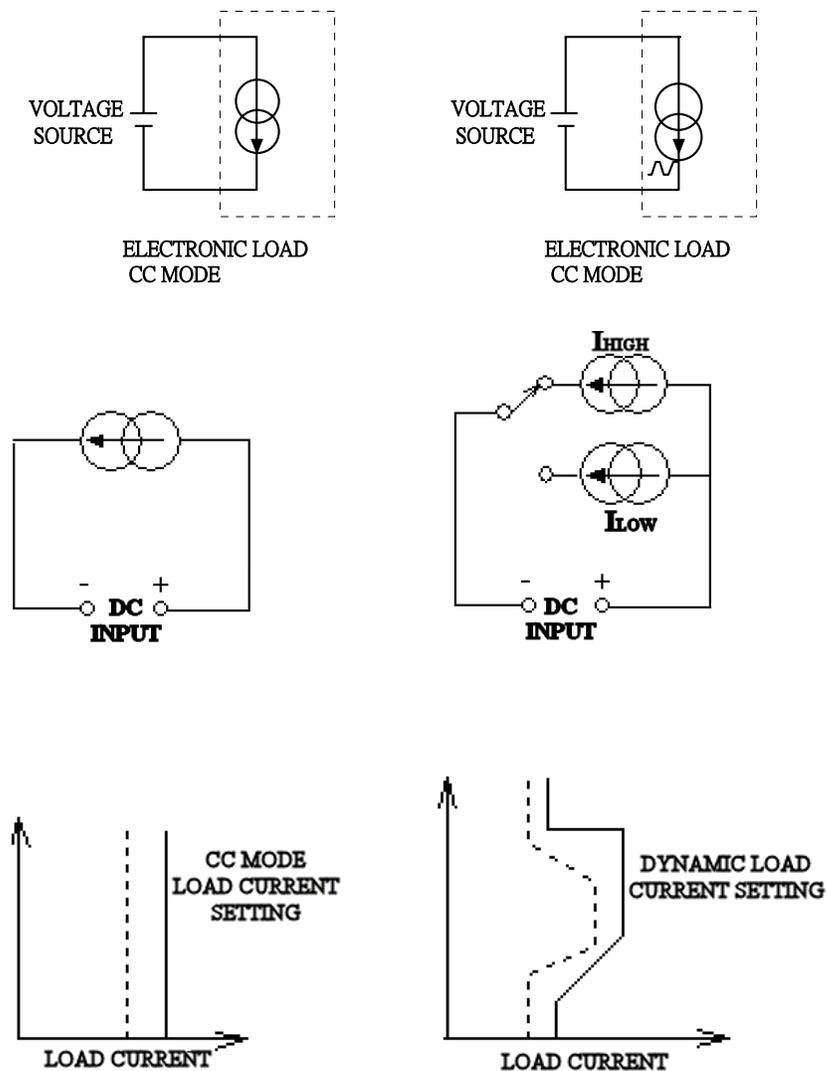

Figure 4-3 Constant Current Mode Application

4.3.2 Dynamic Mode:

Major application:

Power supply load transient response testing, power recovery time testing, pulse load simulation, power component testing

Description:

The maximum Rise/Fall current slew rate or minimum Rise/fall time is the time required for the load input to change from 10% to 90% or from 90% to 10% of the programmed High to Low load level.

- Rise slew rate = $|I_{low} - I_{high}| / T_a$ (A/us)
- Fall slew rate = $(I_{high} - I_{low}) / T_b$ (A/us)
- Rise time = $T_a = |I_{low} - I_{high}| / \text{Rise slew rate}$
- Fall time = $T_b = (I_{high} - I_{low}) / \text{Fall slew rate}$

Built-in Pulse Generator: (Fig 4-4)

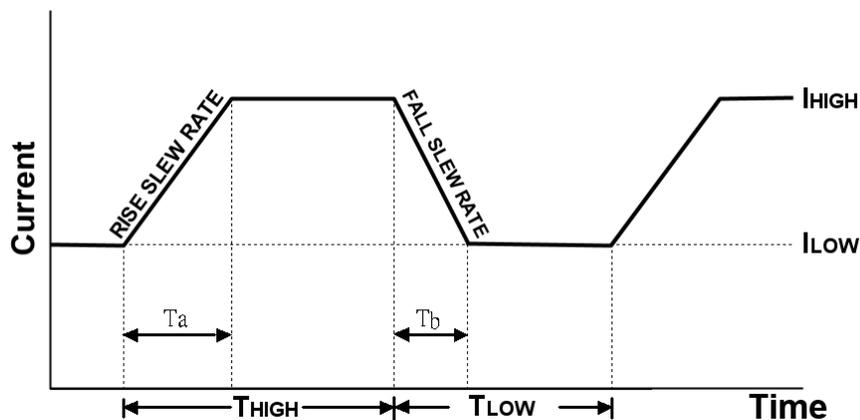

Figure 4-4 Dynamic Load Current with Independent Programmed Rise/Fall Slew Rate

4.4 Constant Voltage (CV) Mode Application

Major application: Current source testing, power supply current limit characteristic testing

Current Source Testing

Battery chargers are among the most common current sources; they are used to inputs current to a re-chargeable battery. The CV mode of electronic load can be used to simulate the terminal voltage of re-chargeable battery, to test the current being generated by the battery charger.

For example, CV mode can be used to first set voltage and read the charge current from the current meter on the load; then set CV voltage to 5V (example), then read the charge current again, this method is used to test the load regulation of a current source.

Current Limit Testing

A lab power supply could use the fold-back current limit test for a switching power supply, to find the constant current limit curve. CV mode is effective for such testing.

For example, the user can set CV voltage, record the output current, then run a series of voltage and current to get an output current limit curve (Figure 4-5) of a power supply.

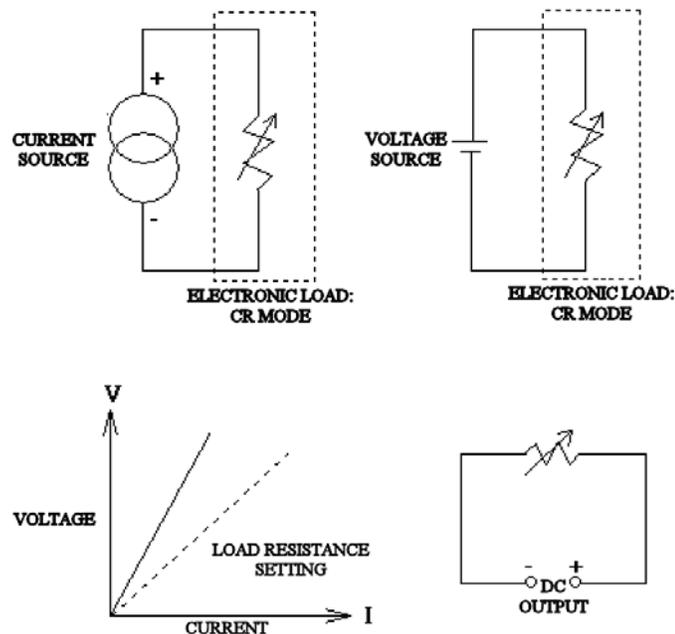

Figure 4-5 Constant Voltage Mode Application

4.5 Constant Resistance (CR) Mode Application

Major application: voltage source testing, current source testing, power supply power-up sequence

CR mode can be used in conjunction with CC mode when testing switching power supplies, to avoid shutdown.

For example, if CC mode alone were used in test set up, a 5V/50A output power supply cannot deliver 50A over its start-up range of 0-5 volts. In many cases, the power supply short circuit or over current protection circuit will shut the power supply down because it can't deliver enough current at low voltage. This is due to the power supply trying to deliver 50A at 2V because the load is in CC mode.

Therefore, when testing a power supply, the CR mode can be used to allow the power supply voltage and current to ramp up together. After ramp-up the CC mode should be used to complete testing. The need for manually switching from the CR to the CC mode is eliminated with SLM-series DC electronic loads. They can be programmed with proper current and slew rate in the CC mode, which allows a power supply to reach its specified output condition in the CC load mode.

Note: Vsense input should be connected when running in CR mode to avoid resistance variation due to the cable resistance.

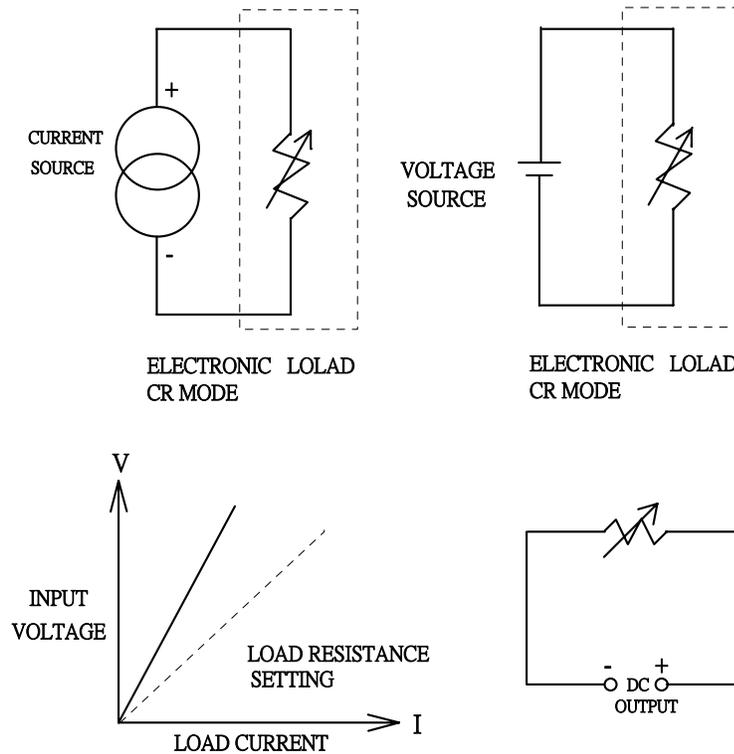

Figure 4-6 Constant Resistance Mode Application

4.6 Constant Power (CP) Mode Application

Major Application: Test and evaluate a battery's energy capacity.

Primary or secondary battery is the power source for every portable electronics product, such as notebook computer, video camera, etc. A typical sequence of battery output is where the output voltage of battery begins to drop (Figure 4-7a) according to the output current and usage duration. (Figure 4-7b); however, it should provide a stable power output regardless of output voltage (Figure 4-7c), therefore, the energy capacity (output power x time) is one of the most important factors in evaluating a battery.

In CP mode, the SLM-series DC electronic load can sink constant power load for a battery; the load current increases as the battery's output voltage drops; the load power will remain equal to the load power setting of CP mode (Figure 4-7d), the SLM-series DC electronic load in CP mode with time record can be used to evaluate the energy capacity or discharge life time of a battery.

Moreover, the real power could be a dynamic loading condition. The SLM-series DC CP mode can be operated in Dynamic power load as well, setting the STA/DYN to DYN on the front panel or remote programming, SLM-series DC load can sink dynamic power waveform to test the dynamic characteristics of battery (Figure 4-7e).

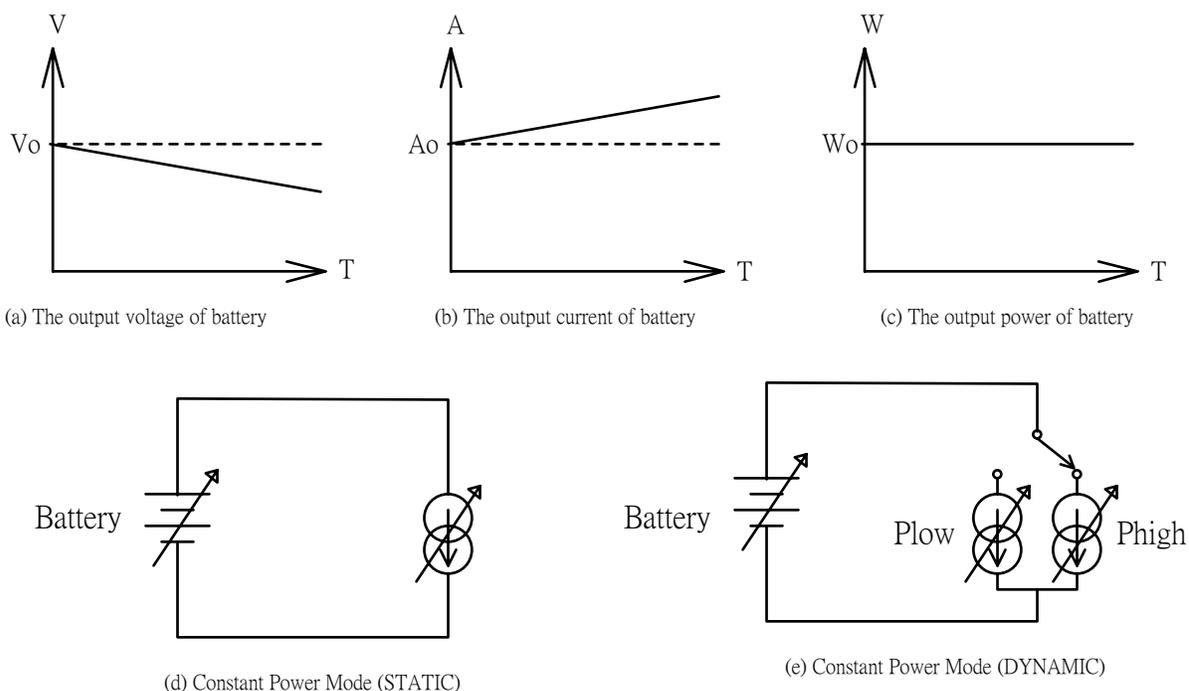
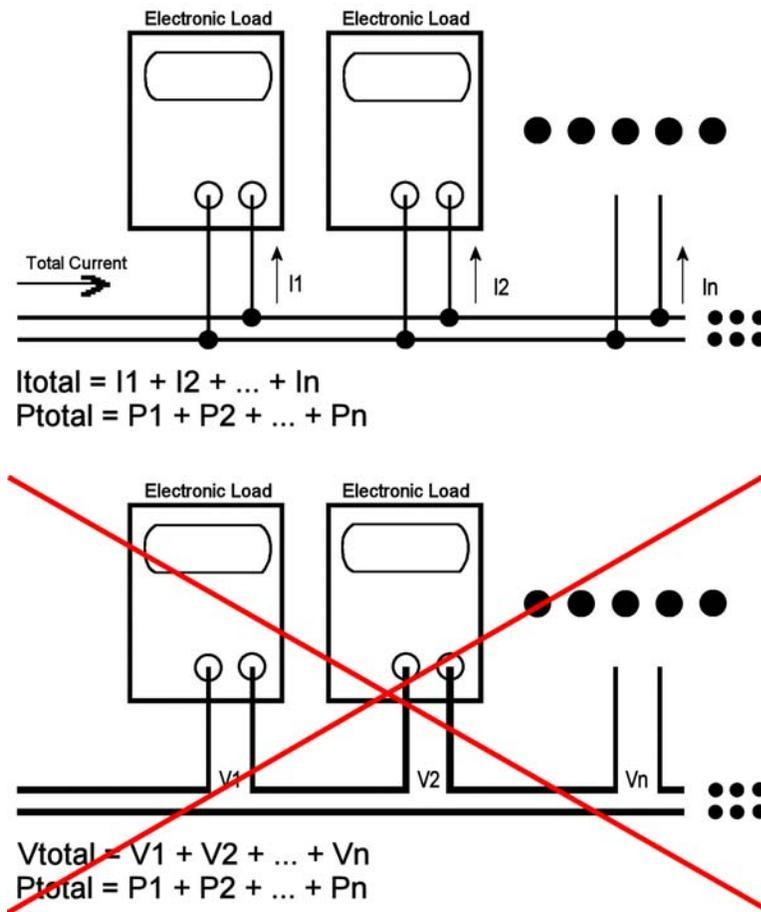

Figure 4-7 Constant Power Mode Application

4.7 Parallel Operation

When there is insufficient power or current rating on the electronic load module, two or more electronic load modules can be paralleled to operate as one unit. A parallel connection can extend the electronic load module to a higher power and current rating. In such a case, the total load current and power is equal to the sum of the two or more load modules.



**Figure 4-8 SLM-Series DC Plug-in Load Module Parallel Operation (top)
Series connection not allowed (bottom)**

SECTION 5

REMOTE PROGRAMMING

The rear panel of the SLM mainframe is designed to connect with a PC (Personal Computer) or Notebook PC through GPIB or RS-232 interfaces.

5.1 GPIB Commands

The following GPIB setting commands are *channel-dependent*, except the "CHAN" command, which is *channel-specific*; therefore, for proper testing program execution, the *channel-specific* command "CHAN" should be sent first, followed by the *channel-dependent* command.

Example:

Short ON of channel 1 of SLM-series Electronic Load module, the GPIB programming command is: CHAN 1:SHOR ON.

The following GPIB commands with [GLOB:] option can set all the SL-series load modules in the SLM mainframe to be active simultaneously. This feature can greatly reduce the testing time and increase efficiency.

5.2 RS-232 Interface and Commands

The following RS-232 commands are the same as GPIB commands. The RS-232 protocol in SLM mainframe is listed as follows:

BAUD-RATE	9600
Parity	none
Data bit	8 bits
Stop bit	1 bit
Command delay time	20 msec.

The connections for the rear panel RS-232 interface are shown below; Figure 5-1-A depicts the connector wire diagram, and Figure 5-1-B depicts the connections using a standard RS-232 cable.

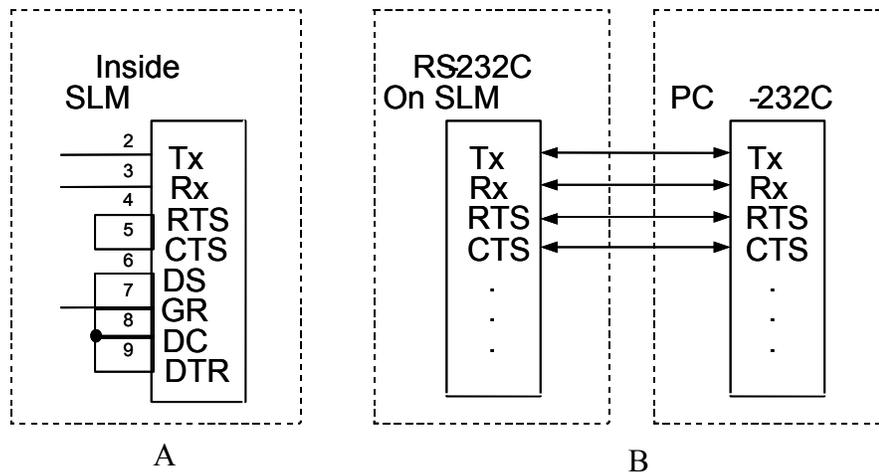

Figure 5-1 RS-232 Interface Diagram

The following RS-232 setting commands are *channel-dependent* commands except "CHAN" which is a *channel-specific* command; therefore, for proper program execution "CHAN" should be sent first, and then the *channel-dependent* command.

For example:

Short ON of Channel 1 of SL-series Electronic Load module, the RS-232 programming command is: CHAN 1;SHOR ON.

As with the GPIB commands, the following RS-232 commands with [GLOB:] option can set all the SL-series Electronic load modules in the SLM mainframe to be active simultaneously. This feature can greatly reduce the testing time and increase efficiency.

5.3 GPIB/RS-232C Command List

5.3.1 Command Syntax Abbreviations

- SP** :Space, the ASCII code is 20 Hexadecimal.
- ;** :Semicolon, Program line terminator, the ASCII code is 0A Hexadecimal.
- NL** :New line, Program line terminator, the ASCII code is 0A Hexadecimal.
- N** :Integer from 1 to 8.
- NR2** :Digits with decimal point. It can be accepted in the range and format of **##.#####**.

Example: 30.12345, 5.0

Description of GPIB Programming Command Syntax.

- { } :The contents of the { } symbol must be used as a part or data of the GPIB command, it can not be omitted.
- [] :The contents of the [] symbol indicates that the command is optional, depending on the testing application.
- | :This symbol means to make a choice between one or the other. For example “ HIGH|LOW ” means it can only use HIGH or LOW as the command, but one of the choices must be used.
- Terminator :The program line terminator character must be sent after the GPIB command; the available command terminator characters that can be accepted in the SLM mainframe are listed in Table 5-1.

LF
LF WITH EOI
CR, LF
CR, LF WITH EOI

Table 5-1 GPIB Command Terminator

A terminator informs GPIB that it has reached the end of statement. Normally, this is sent automatically by your GPIB programming statements. In this manual, the terminator is assumed at the end of each example line of code. If it needs to be indicated, it is shown by symbol (nl); which stand for “ new line” and represents ASCII code byte the OA Hexadecimal or 10 decimal.

- Semicolon “;“ :The semicolon “ ;” is a back-up command, the semicolon allows you to combine command statements on one line to create command message.

Table 5-2 presents a summary of the GPIB/RS-232 Setting commands, and Table 5-3 summarizes the GPIB/RS-232 preset Query commands with applicable module types. Table 5-4 is a summary of State commands, the System commands are in Table 5-5, Measure and Limit commands are in Table 5-6, and the Global commands are in Table 5-7.

Setting Preset Numeric Command	Model			Remark
	SLM DC	SLD	SLM AC	
[PRESet:] BANK{SP}{d}{; NL}			•	d=0~30
[PRESet:] WAVE{SP}{m}{; NL}			•	M=0~5
[PRESet:] FREQuency{SP}{NR2}{; NL}			•	40.0~70.0Hz
[PRESet:] RISE{SP}{NR2}{; NL}	•			
[PRESet:] FALL{SP}{NR2}{; NL}	•			
[PRESet:] SLEWrate{SP}{NR2}{; NL}		•		
[PRESet:] PERIod:{HIGH LOW}{SP}{NR2}{; NL}	•	•		
[PRESet:] LDONv{SP}{NR2}{; NL}	•	•		
[PRESet:] LDOFfv{SP}{NR2}{; NL}	•	•		
[PRESet:] CC{SP}{NR2}{; NL}		•		
[PRESet:] CC:{A B}{SP}{NR2}{; NL}			•	
[PRESet:] CC:{HIGH LOW}{SP}{NR2}{; NL}	•	•		
[PRESet:] CP:{HIGH LOW}{SP}{NR2}{; NL}	•			
[PRESet:] CR{SP}{NR2}{; NL}		•		
[PRESet:] CR:{A B}{SP}{NR2}{; NL}			•	
[PRESet:] CR:{HIGH LOW}{SP}{NR2}{; NL}	•			
[PRESet:] CV:{HIGH LOW}{SP}{NR2}{; NL}	•			
[PRESet:] CV{SP}{NR2}{; NL}		•		

Table 5-2 GPIB/RS-232 Setting Command Summary

Query Preset Numeric Command	Model			RETURN
	SLM DC	SLD	SLM AC	
[PRESet:] BANK{SP}{?}{; NL}			•	0~10
[PRESet:] WAVE{SP}{?}{; NL}			•	1~5
[PRESet:] FREQuency{?}{; NL}			•	40.0~70.0
[PRESet:] RISE{?}{; NL}	•			###.####
[PRESet:] FALL{?}{NR2}{; NL}	•			###.####
[PRESet:] SLEWrate{?}{; NL}		•		###.####
[PRESet:] PeRIod:{HIGH LOW}{?}{; NL}	•	•		###.####
[PRESet:] LDONv{?}{; NL}	•	•		###.####
[PRESet:] LDOFfv{?}{; NL}	•	•		###.####
[PRESet:] CC{?}{; NL}		•		###.####
[PRESet:] CC:{A B}{?}{; NL}			•	###.####
[PRESet:] CC:{HIGH LOW}{?}{; NL}	•	•		###.####
[PRESet:] CP:{HIGH LOW}{?}{; NL}	•			###.####
[PRESet:] CR{?}{; NL}		•		###.####
[PRESet:] CR:{A B}{?}{; NL}			•	###.####
[PRESet:] CR:{HIGH LOW}{?}{; NL}	•	•		###.####
[PRESet:] CV:{HIGH LOW}{?}{; NL}	•			###.####
[PRESet:] CV{?}{; NL}		•		###.####

Table 5-3 GPIB/RS-232 Preset Query Command Summary with Applicable Module Types

STATE Command	Model			RETURN
	SLM DC	SLD	SLM AC	
[STAtE:] LOAD{SP}{ON OFF}; NL}	•	•	•	
[STAtE:] LOAD{?}; NL}	•	•	•	0=OFF, 1=ON::
[STAtE:] MODE{SP}{CC CR CV CP}; NL}	•	•	•	
[STAtE:] MODE{?}; NL}	•	•	•	0=:CC, 1=:CR 2=:CV, 3=:CP
[STAtE:] SHORt{SP}{ON OFF}; NL}	•	•	•	
[STAtE:] SHORt{?}; NL}	•	•	•	0=OFF, 1=ON::
[STAtE:] PRESet{SP}{ON OFF}; NL}	•	•	•	
[STAtE:] PRESe{?}; NL}	•	•	•	0=OFF, 1=ON::
[STAtE:] SENSE{SP}{ON OFF}; NL}	•	•	•	
[STAtE:] SENSE{?}; NL}	•	•		0=OFF, 1=ON::
[STAtE:] RANGE{SP}{I II}; NL}				
[STAtE:] RANGE{?}; NL}				0:I, 1:II
[STAtE:] LEVEl{SP}{HIG LOW AIB}; NL}	•		•	
[STAtE:] LEVEl{?}; NL}	•		•	0=:LOW, 1=:HIGH
[STAtE:] DYNAmic{SP}{ON OFF}; NL}	•	•		
[STAtE:] DYNAmic{?}; NL}	•	•		0=:OFF, 1=:ON
[STAtE:] SYNCRonize{SP}{ON OFF}; NL}			•	
[STAtE:] SYNCRonize{?}; NL}			•	0=OFF, 1=ON::
[STAtE:] WATT{SP}{ON OFF}; NL}	•		•	
[STAtE:] WATT{?}; NL}	•		•	0=OFF, 1=ON::
[STAtE:] CLEar{ NL}	•	•	•	
[STAtE:] ERRor{?}; NL}	•	•	•	Dddddddd
[STAtE:] DUAL{SP}{DVM DAM OFF}; NL}		•		
[STAtE:] PARAllel{SP}{ON OFF}; NL}		•		
[STAtE:] NGAB{SP}{ON OFF}; NL}		•		0=:OK, 1=:NG
[STAtE:] NGAB{?}; NL}		•		0=:OK, 1=:NG
[STAtE:] NG{?}; NL}	•	•	•	0=:OK, 1=:NG
[STAtE:] PROTEct{?}; NL}	•	•	•	Dddddddd

Table 5-4 State Command Summary

COMMAND	NOTE	RETURN
[SYStem:] CHANnel{SP}{1 2 3 4}[A B]; NL}		
[SYStem:] CHANnel{SP}{?}; NL}		{1 2 3 4}[A B]
[SYStem:] RECall{SP}{m[,n]}; NL}	M=1~5 n=1~30	
[SYStem:] STORe{SP}{m[,n]}; NL}	M=1~5 n=1~30	
[SYStem:] REMOTE; NL}	Only RS232 cmd	
[SYStem:] LOCAL; NL}	Only RS232 cmd	0=:OFF, 1=:ON
[SYStem:] NAME{?}; NL}		" XXXXX"

Table 5-5 System Commands - All Modules

COMMAND	SLM DC	SLD	SLM AC	RETURN
MEASure:CURRent {?}; NL}	•	•	•	###.###
MEASure:VOLTage {?}; NL}	•	•	•	###.###
MEASure:PWR {?}; NL}			•	###.###
MEASure:VA {?}; NL}			•	###.###
LIM:CURRent:{HIGH LOW};{SP}{NR2}; NL}	•	•	•	
LIM:CURRent:{HIGH LOW};{?}; NL}	•	•	•	###.###
LIM:POWer:{HIGH LOW};{SP}{NR2}; NL}	•		•	
LIM:POWer:{HIGH LOW};{?}; NL}	•		•	###.###
LIM:VA:{HIGH LOW};{SP}{NR2}; NL}			•	
LIM:VA:{HIGH LOW};{?}; NL}			•	###.###
LIM:VOLTage:{HIGH LOW};{SP}{NR2}; NL}	•	•	•	
LIM:VOLTage:{HIGH LOW};{?}; NL}	•	•	•	###.###

Table 5-6 Measure and Limit Commands

COMMAND	SLM DC	SLD	SLM AC	RETURN
GLOBal:[STAtE:] PRESet{SP}{ON OFF}; NL}	•	•	•	
GLOBal:[STAtE:] LOAD{SP}{ON OFF}; NL}	•	•	•	
GLOBal:[STAtE:] MODE{SP}{ON OFF}; NL}	•	•	•	
GLOBal:[STAtE:] SHORt{SP}{ON OFF}; NL}	•	•		
GLOBal:[STAtE:] DYNAmic{SP}{ON OFF}; NL}	•	•		
GLOBal:[STAtE:] LEVEl{SP}{HIGH LOW}; NL}	•			
GLOBal:[STAtE:] LEVEl{SP}{A B}; NL}			•	
GLOBal:[STAtE:] RANGe{SP}{ I }; NL}	•	•		
GLOBal:MEASure:CURRent{?}; NL}	•	•	•	###.##
GLOBal:MEASure:VOLTage{?}; NL}	•	•	•	###.##

Table 5-7 Global Commands

REMARKS:

1. d : 0 - 9
2. GLOB : GLOBAL (ALL CHANNELS ACTIVE AT SAME TIME)
3. CURRENT ENGINEERING UNIT : A
4. VOLTAGE ENGINEERING UNIT : V
5. RESISTANCE ENGINEERING UNIT : Ω
6. PERIOD ENGINEERING UNIT : mS
7. SLEW-RATE ENGINEERING UNIT : A/ μ S

Note: The RS-232 command set is the same as the GPIB command set.

5.4 GPIB/RS-232 Command Description

5.4.1 Setting Commands

CHANNEL

Purpose:

"CHAN" selects the multiple Electronic load channel to which all subsequent channel-specific commands will be directed.

Command Syntax:

All Modules: CHAN{SP}n{;NL}

Description:

"CHAN" command selects the specified Electronic load module from 1 through 4 as the Electronic load module number (from left to right). Up to 4 channels of the Electronic load module can be installed in one mainframe. This command is a channel *independent* command; therefore, this command should be programmed before an electronic load channel *dependent* command.

The load channel number is arranged as 1, 2, 3, 4 from left side to the right side. Module SLD-60-105-550 is a dual bay module that utilizes the channel number corresponding to the bay occupied by the right side of the module. E.g., if a dual bay module takes up bays 1 and 2, its channel number shall be 2.

Example:

CHAN 2 select channel 2 of SL-series mainframe.

Note:

Please refer to Appendices C, D and E for proper programming procedure of SL-series electronic load modules.

CURRENT Level

Purpose:

The load current setting in Constant Current mode.

Command Syntax:

All SLM Modules: CC:{LOW|HIGH}{SP}{NR2}{;NL}

SLD Modules: CC{SP}{NR2}{;NL}

Description:

CC:{LOW|HIGH}{SP}{NR2}{;|NL}

Sets the current level of SLM-series AC or DC Electronic Load modules.

CC:{SP}{NR2}{;|NL}

This command is used to set the load current level for CC static mode of SLD-series electronic load module.

Note:

- a. The load current data must include the decimal point; otherwise, this command will not execute. The load current level can be programmed up to the sixth place after the decimal point.
- b. The HIGH level load current MUST be higher than the LOW level load current (and vice versa) for proper dynamic waveform definition; if not, the SLM-series Electronic Load will adjust and limit the programmed values to be equal. The adjustment matches the second input value to the first input value.
This means that if the value for the LOW level is input first, and then the HIGH level value is input as less than the programmed LOW level, the SLM-series load module will adjust the HIGH level to be equal to the LOW level. If the value for the HIGH level is input first and the LOW level value is input as higher than the programmed HIGH level, the SLM-series load module will adjust the LOW level to be equal to the HIGH level.
- c. If the programmed load current level is over the maximum rated specification, the full scale current will be sent to the load module.
- d. Engineering unit for load current is Amps.
- e. Please refer to Appendices C, D and E for proper programming procedure of SL-series electronic load modules.

Example:

CC:LOW 1.8 set LOW level load current to 1.8 A.

CC:HIGH 25.123456 set HIGH level load current to 25.123456 A.

RESISTANCE Level**Purpose:**

The load resistance setting in Constant Resistance mode.

Command Syntax:

All SLM Modules: CR:{HIGH|LOW}{SP}{NR2}{;|NL}

SLD Modules CR:{SP}{NR2}{;|NL}

Description:

CR:{HIGH|LOW}{SP}{NR2}{;|NL}

This command is used to set the LOW/HIGH load resistance level of SLM series AC and DC electronic load module.

CR:{SP}{NR2}{;|NL}

This command is used to set the load resistance level of SLD-Series load module.

Note:

- a. The load resistance data must include the decimal point; otherwise, this command will

- not execute. The load resistance level can be programmed up to the sixth place after the decimal point.
- b. The HIGH level load resistance MUST be higher than the LOW level load resistance (and vice versa) for proper dynamic waveform definition; if not, the SLM-series Electronic Load will adjust and limit the programmed values to be equal. The adjustment matches the second input value to the first input value. This means that if the value for the LOW level is input first, and then the HIGH level value is input as less than the programmed LOW level, the SLM-series load module will adjust the HIGH level to be equal to the LOW level. If the value for the HIGH level is input first and the LOW level value is input as higher than the programmed HIGH level, the SLM-series load module will adjust the LOW level to be equal to the HIGH level.
 - c. If the programmed load resistance level is over the maximum rated specification, the full scale resistance will be sent to the load module.
 - d. Engineering unit for load resistance is Ohms.
 - e. Please refer to Appendices C, D and E for proper programming procedure of SL-series electronic load modules.

Example:

CR:LOW 0.123 set LOW level load resistance to 0.123 OHM.

CR:HIGH 3.456789 set HIGH level load resistance to 3.456789 OHM.

VOLTAGE Level**Purpose:**

The load voltage setting in Constant Voltage mode.

Command Syntax :

SLM DC Modules: CV:{HIGH|LOW}{SP}{NR2}{;|NL}

SLD Modules: CV:{SP}{NR2}{;|NL}

Description:

CV:{HIGH|LOW}{SP}{NR2}{;|NL}

This command is used to set the load voltage level of SLM-series DC electronic load modules.

CV {SP}{NR2}{;|NL}

This command is used to set the load voltage level of SLD-series electronic load modules.

Notes:

- a. The load voltage data must include the decimal point; otherwise, this command will not execute. The load voltage level can be programmed up to the sixth place after the decimal point.
- b. The HIGH level load voltage MUST be higher than the LOW level load voltage (and vice versa) for proper dynamic waveform definition; if not, the SLM-series Electronic Load will adjust and limit the programmed values to be equal. The adjustment matches the second input value to the first input value. This means that if the value for the LOW level is input first, and then the HIGH level value is input as less than the programmed LOW level, the SLM-series load module will adjust the HIGH level to be equal to the LOW level. If the value for the HIGH level is input first and the LOW level value is input as higher than the programmed HIGH level, the SLM-series load module will adjust the LOW level to be equal to the HIGH level.

- c. If the programmed load voltage level is over the maximum rated specification, the full scale voltage will be sent to the load module.
- d. Engineering unit for load current is Volts.
- e. Please refer to Appendices C, D and E for proper programming procedure of SL-series electronic load modules.

Example:

CV:LOW 3.0 set LOW level load voltage to 3.0 V.

CV:HIGH 45.123456 set HIGH level load voltage to 45.123456 V.

POWER Level**Purpose:**

The load power setting in Constant Power mode.

Command Syntax:

SLM DC Modules: CP:{HIGH|LOW}{SP}{NR2}{;|NL}

Description:

This command is used to set the load Power level of electronic load modules.

Note : Mode CP is available in SLM-series DC loads only.

LOAD ON/OFF**Purpose:**

Turn the Electronic load module input ON or OFF.

Command Syntax:

All Modules: [GLOB:]LOAD{SP}{OFF|ON}{NL}

Description:

This command sets the Electronic load to sink current from power source. GLOB:LOAD ON All the Electronic load modules in the SLM mainframe are ready to sink current from power source.

For Example :

GLOB:LOAD OFF ; All load modules in the SLM mainframe are at input OFF condition.

CHAN 3:LOAD ON ; Set the channel 3 load module to LOAD ON status, this load module is ready to sink current from the power source.

CHAN 1:LOAD 0; Set the channel 1 load module to LOAD OFF.

LOAD ON VOLTAGE Setting**Purpose:**

The Load ON voltage setting (Initial is 1.0V) of DC electronic load modules.

Command Syntax:

All Modules: LDON{SP}{NR2}{;|NL}

Description:

The Load On voltage can be adjusted by the LDON command. The range is 0.1-25.0 V (Res. = 0.1V). The load will start to sink current if power source output voltage is higher than Load On voltage.

For Example:

LDON 2.5; Set the Load On voltage to 2.5V, The load will start to sink current when the power source output voltage is higher than 2.5V.

LOAD OFF VOLTAGE Setting**Purpose:**

The Load OFF voltage setting (Initial is 0.5V) of DC electronic load modules.

Command Syntax:

All Modules: LDOF{SP}{NR2}{;|NL}

Description:

The Load Off voltage can be adjusted by the LDOF command; the adjust range is 0.1-load on voltage (Res. = 0.1V. The load will stop to sink current if power source output voltage is lower than Load Off voltage.

For Example :

LDOF 2.0 ; Set the Load Off voltage to 2.0V. The load will start to sink current when power source output voltage is lower than 2.0V.

LEVEL HIGH/LOW**Purpose:**

Select Low or High level in static mode, of DC electronic loads, or LEVEL A/B of AC electronic loads.

Command Syntax:

All Modules: [GLOB:] LEVE {SP}{HIGH|LOW}{NL}

Description:

LEVE LOW is Set LOW current level in CC mode, LOW resistance level in CR mode, or LOW voltage level in CV mode at the active load channel.

LEVE 1 is Set HIGH current level in CC mode, HIGH resistance level in CR mode, or HIGH voltage level in CV mode at the active load channel.

PRESET ON/OFF**Purpose:**

Set the upper or lower digit multi-function meter to display the programming load level.

Command Syntax:

All Modules: [GLOB:]PRES{SP}{0|1|OFF|ON}{NL}

Description:

GLOB:PRES ON is set all the load module in the SLM mainframe to preset on status.

MODE**Purpose:**

Select the operating mode of Electronic load module.

Command Syntax:

All Modules: [GLOB:]MODE{SP}{0|1|2|3|CC|CR|CV|CP}{NL}

Description:

GLOB:MODE CC ; set the presently operating mode to Constant Current mode for all of the load module in the SLM mainframe.

MODE CV ; set the presently operating mode to Constant Voltage mode.

MODE 1 ; set the presently operating mode to Constant Resistance mode.

MODE CP ; set the presently operation mode to Constant Power mode.

Note:

MODE CV is available in DC loads only.

MODE CP is available in DC, single input loads only.

CLEAR status register

Purpose:

CLEAR the PROT and ERR status byte registers.

Command Syntax:

All Modules: CLER{NL}

Description:

CLER ; clear the PROT and ERR status byte register, the PROT and ERR status byte register will indicate “ 0” after executing the CLER command.

STORE

Purpose:

STORE the load level and load status into the memory of the SL-series electronic LOAD.

Command Syntax:

SLM DC, SLD Modules: STOR{SP}{m[,n]};|NL}

SLM AC Modules STOR{SP}{m};|ML}

Description:

Parameter m is 1~5 for 5 different states with SL-series electronic load module's load status and load current into the non-volatile memory.

Parameter n is 1-30 for 30 memory bank for 150 (m*n) different state with DC electronic load module's load status and load current into the EEPROM memory in the electronic loads.

Example:

STORE 1; store the AC electronic load module's load status and load current into the memory 1.

STORE 2,30; store the DC electronic load module's load status and load current into the memory 147.

RECALL

Purpose:

Recall the state of load level and status, is stored by the GPIB/RS232 STORE command.

Command Syntax:

SLM DC, SLD Modules: REC{SP}{m[,n]};|NL}

SLM AC Modules: REC{SP}{m};|NL}

Description:

This command is used to recall the memory state, is stored into memory by the GPIB/RS232 STORE command, up to 5 states can be recalled for AC electronic load modules, and up to 150 states can be recalled for DC electronic load modules.

Example:

REC 1; Recall the state of load level and status that is stored in memory 1 by GPIB/RS232 STORE command.

REC 147; Recall the state of load level and status that is stored in memory 147 by GPIB/RS232

STOR command.

SYNCHRONOUS ON/OFF

Purpose:

To set synchronous function ON/OFF of SLM AC series electronic load module.

Command Syntax:

SLM AC Modules: SYNC{SP}{0|1|OFF|ON}{;|NL}

Description:

1. External synchronous signal (SYNC ON): Using external synchronous signal as the synchronous triggering signal of the electronic load, synchronizing the load current with the voltage.
2. Internal synchronous signal (SYNC OFF): Using the signal at the terminal of the input connector thus generating synchronous signal through the internal zero-crossing circuit and isolated circuit.

Example:

SYNC ON ; To set external synchronization.

SYNC OFF ; To set internal synchronization.

WATT Meter ON/OFF

Purpose:

To set display of power meter of SLM AC series electronic load module.

Command Syntax:

SLM AC Modules: WATT{SP}{0|1|OFF|ON}{;|NL}

Description:

This command is to set the power meter display. This command must be used in conjunction with PRES:OFF. When setting to ON, the top monitor will change from voltmeter to Watt meter while the monitor at the bottom will change from ammeter to Volt-Ameter (VA) and the unit is “ W” and “ VA” respectively. When setting to OFF, the Watt meter on the top will change back to voltmeter while the VA meter at the bottom will change back to ammeter and the unit is “ Vrms” and “ Arms” respectively.

Example:

PRES OFF

WATT ON ; to display WATT, VA meter.

WATT OFF ; to display Voltage, Current meter.

WAVEFORM BANK

Purpose:

To set waveform bank for AC electronic load modules.

Command Syntax:

SLM AC Modules: BANK{SP}{d}{;|NL} d:0-10

Description:

This command is to set the desired waveform bank.

1. waveform bank 0-4 are sine wave.
2. waveform bank 5-9 are square wave.

3. waveform bank 10 is DC.
4. There are five (5) waveforms for each of eleven (11) waveform banks for a total of 55 waveforms. Waveform information is shown in Table 5-8.

Example:

BANK 1, to set waveform bank 1.

BANK 10, to set waveform bank 10.

	Waveform Bank	m=1	m=2	m=3	m=4	m=5
Sine Wave	0	$\sqrt{2}$	2.0	2.5	3.0	3.5
	1	1.5	1.6	1.7	1.8	1.9
	2	2.0	2.1	2.2	2.3	2.4
	3	2.5	2.6	2.7	2.8	2.9
	4	3.0	3.1	3.2	3.3	3.4
Square Wave	5	1.0	1.1	1.2	1.3	1.4
	6	1.5	1.6	1.7	1.8	1.9
	7	2.0	2.1	2.2	2.3	2.4
	8	2.5	2.6	2.7	2.8	2.9
	9	3.0	3.1	3.2	3.3	3.4
DC	10	$\sqrt{2}$ dc	2dc	2.5dc	3.0dc	3.5dc

Table 5-8 Waveform Information

WAVEFORM**Purpose:**

To set waveform for AC electronic load modules.

Command Syntax:

SLM AC Modules: WAVE{SP}{m}{;|NL} m:1-5

Description:

This command is to set the current Crest Factor (C.F.) at CC MODE (Peak Value Factor).

This command works only at CC MODE. When BANK varies, these 5 sets of C.F. will at the same time define different C.F. as shown in Table 5-8. For details, please refer to SLM AC Operation Manual.

Example:

WAVE 2 ; To set 2nd set C.F.

WAVE 5 ; To set 5th set C.F.

FREQUENCY**Purpose:**

Setting of Frequency Value for AC electronic load modules.

Command Syntax:

SLM AC Modules: FREQ{SP}{NR2}{;|NL}

Description:

This command is for setting the frequency value of electronic load. To use this command, attention must be paid to the following items:

1. The frequency value designated must include the decimals; otherwise, the command will become null and void.
2. The minimum effective digit of the value is the fifth place after the decimal point.
3. If the value designated exceeds the specification of the electronic load, the mainframe will send out the full-scale current value of the electronic load specification.
4. The frequency range is 40.0~70.0Hz.
5. The engineering unit for frequency is Hz.

Example:

FREQ 50.0, to set frequency is 50.0Hz.

FREQ 60.0, to set frequency is 60.0Hz.

FREQ 0.1, to set frequency is 0.1Hz, that is to set DC.

VOLTAGE Limit**Purpose:**

To set the upper/lower limit value of threshold voltage.

Command Syntax:

All Modules: LIM:VOLT:{HIGH|LOW}{SP}{NR2}{;|NL}

Description:

This command is to set the upper/lower limit value of threshold voltage. When input voltage is lower than the lower limit value or higher than the upper limit value, NG indicating light will come on to indicate " NO GOOD."

Example:

LIM:VOLT:LOW 1.0 ; To set the lower limit value of threshold voltage to 1.0 V.

LIM:VOLT:HIGH 200.0 ; To set the upper Limit vale of threshold voltage to 200.0V.

CURRENT Limit**Purpose:**

To set the upper/lower limit value of threshold current.

Command Syntax:

All Modules: LIM:CURR{HIGH/LOW}{SP}{NR2}{;|NL}

Description:

This command is to set the lower limit value of threshold current. When load sink current is lower than this lower limit value or higher than the upper limit value, NG indicating light will come on to indicate "NO GOOD."

Example:

LIM:CURR:LOW:0.05 ; To set the lower limit value of threshold current to 0.05A.

LIM:CURR:HIGH:10.0 ; To the upper limit value of threshold current to 10.0A.

POWER Limit

Purpose:

To set the upper/lower limit value of threshold power (W).

Command Syntax:

SLM DC Modules: LIM:POW:{HIGH|LOW}{SP}{NR2}{;|NL}

Description:

This command is to set the upper/lower limit value of threshold power (WATT). When power (WATT) is lower than this lower limit value or higher than the upper limit value, NG indicating light will come on to indicate "NO GOOD."

Example:

LIM:POW:LOW 0.05 ; To set the lower limit value of threshold power (W) to 0.05 W.

LIM:POW:HIGH 250.0 ; To set the upper limit value of threshold power(W) to 250.0 W.

VA Limit

Purpose:

To set the upper/lower limit value of threshold power (VA).

Command Syntax:

SLM AC Modules: LIM:VA:{HIGH|LOW}{SP}{NR2}{;|NL}

Description:

This command is to set the upper/lower limit value of threshold power (VA). When power (VA) is lower than this lower limit value or higher than the upper limit Value, NG indicating light will come on to indicate "NO GOOD."

Example:

LIM:VA:LOW 0.05 ; To set the lower limit value of threshold power (VA) is 0.05 VA.

LIM:VA:HIGH 250.0 ; To set the upper limit value of threshold power(VA)is 250.0 VA.

PERIOD

Purpose:

Set the Tlow/Thigh duration of dynamic load in Constant Current mode.

Command Syntax:

SLM DC, SLD Modules: PERI:{LOW|HIGH}{SP}{NR2}{NL}

Description:

The PERIOD of dynamic waveform is composed by Tlow and Thigh. The PERIOD LOW and HIGH data must include decimal point, otherwise this command will not execute.

The value for PERIOD LOW and HIGH can be programmed up to the sixth place after the decimal point. If the period of Tlow and Thigh setting is over the maximum specification at programmed range of load module, the maximum duration of Tlow and Thigh will be sent to the load module.

Please verify the appropriate timer range before executing the load PERI LOW or HIGH command, otherwise the PERI load module will adjust to fit the Tlow and Thigh ranges after programming the PERI LOW or HIGH command. The engineering unit for PERI LOW and HIGH is "ms."

Note:

1. There are four timer ranges in the Tlow / T high generator to produce a wide period dynamic range, these ranges are adjusted by the load module automatically which depends on the programmed Tlow / Thigh range.
2. Example: The load CHA and CHIB USES the same T-high and T-low controller of SLD-series electronic load.

Example:

PERI:LOW 0.125;PERI:HIGH 0.8

Set the LOW dynamic load duration to 0.125 ms, and the HIGH dynamic load duration to 0.8 ms.

RISE Time**Purpose:**

RISE load current slew rate setting.

Command Syntax:

SLM DC Modules: RISE{SP}{NR2}{NL}

Description:

The RISE load current slew rate of load level change or dynamic load can be programmed by RISE command. The RISE slew rate of SLM-series DC electronic load modules can be fully independent from the FALL slew rate.

The RISE load current slew rate data must include a decimal point, otherwise this command is will not execute.

The value for the RISE load current slew rate can be programmed up to sixth place after the decimal point. If the programming load current level is over the maximum specification at the programmed range of SLM DC series load module, the fastest RISE slew rate will be sent to the load module. Please verify the range I/II command before execute the load RISE slew rate setting command, otherwise the SLM DC load module will adjust to fit the RISE slew rate after programming the RISE command. The engineering unit for RISE slew rate is "A/us."

Example:

RISE 1.25 set RISE slew rate to 1.25 A/us.

FALL Time**Purpose:**

FALL load current slew rate setting.

Command Syntax:

SLM DC Modules: FALL{SP}{NR2}{NL}

Description:

Programs the FALL load current slew rate of load level change or dynamic load. The FALL slew rate of SLM DC electronic load modules can be fully independent of the RISE slew rate.

The FALL load current slew rate data must include a decimal point, otherwise this command will not execute. The value for FALL load current slew rate can be programmed up to the sixth place after the decimal point. If the programming load FALL slew rate is over the full-scale specification, the fastest FALL slew rate will be sent to the load module. Please verify the range I/II command

before executing the load FALL slew rate setting command, otherwise, the load module will adjust to fit the FALL slew rate after programming the FALL command.

The engineering unit for FALL slew rate is “A/μs”.

Example:

FALL 0.124 set FALL slew rate to 0.124 A/μs.

SLEW Rate

Purpose:

Set the load current slew rate of SLD-series electronic load module.

Command Syntax:

SLD Modules SLEW{SP}{NR2}{;|NL}

Description:

Rise and Fall slew rate is the same for the SLEW command setting of SLD electronic load module.

The Slew rate has two ranges, and it follows the CC mode range change automatically: when CC Dynamic mode is in Range I, the slew rate is in range I, if CC Dynamic mode is in range II, then Slew rate is in range II.

SHORT ON/OFF

Purpose:

Short the DC input of Electronic load module.

Command Syntax:

SLM DC, SLD Modules: [GLOB:]SHOR{SP}{0|1|OFF|ON}{NL}

Description:

This command applies the short across the input of the Electronic load. Executing SHOR does not affect any programmed settings and the Electronic load will return to those settings when the short is removed.

Example:

GLOB:SHOR ON ; set all load module load input to short state.

CHAN 2;SHOR OFF ; set channel 1, 2 load module load input short open state.

SENSE ON/OFF

Purpose:

Set the voltage sense ON/OFF of Electronic load.

Command Syntax:

All Modules: [GLOB:]SENS{SP}{0|1|OFF|ON}{NL}

Description:

Set the Vsense inputs Off or On. If Vsense is set to Off, voltage measurement is taken at the load input terminals. If Vsense is set to On, voltage is measured at the Vsense input. On SLM-series DC loads, Vsense is auto/off or on. If it is set to auto/off, the module will measure the Vsense input if the voltage is greater than 1V (on 60V models) or 3V (on 250 and 500V models).

Example:

GLOB:SENS ON set all load module V-sense input to sense ON state.

CHAN 2;SENS OFF set channel 1, 2 load module V-sense input to sense OFF state.

DYNAMIC ON/OFF

Purpose:

Set DYNamic ON or OFF command.

Command Syntax:

SLM DC, SLD Modules: [GLOB:]DYN{SP}{0|1|OFF|ON}{NL}

Description:

GLOB:DYN OFF ; set all DC load modules in the SLM mainframe to static load mode.

CHAN 4;DYN 1 ; set channel 4 load module to dynamic load mode.

NG Enable /Disable

Purpose:

Set Meter GO/NG check ON or OFF.

Command Syntax:

SLD Modules: NGAB{SP}{OFF|ON}{;|NL}

Description:

Setting NG ON or OFF indicates that the NG check is enabled or disabled; the NG ON or OFF can be changed by NGAB ON/OFF command. The Load GO/NG check includes voltage and current meter GO/NG check, so user can set the current's Upper limit to max. and set the lower to min. if the current meter NG check is not required and vice versa.

Note : When CH A NG is set to OFF, the front panel NG A LED is disabled.

Note : When CH B NG is set to OFF, the front panel NG B LED is disabled.

PARAllel ON/OFF

Purpose:

A // b; Parallel Load Channel A and B for SLD-series electronic load.

Command Syntax :

Common Voltage SLD Modules: PARA{SP}{ON|OFF}{;|NL}

Description:

The parallel ON/OFF command is available for SLD-60-505-255-SLD-60-20-102 and SLD-62-5-752 modules. PARA command to set ON (Parallel) or OFF (Not Parallel). Dual Load parallel operation is available for same polarity load in a module; it can be a two positive or two negative load.

During the parallel loading operation, the load level and status of CH A and B is still independent. Only the current meter shows the CH A + CH B load current on Channel A's and B's current meter; user can use the DUAL command setting to display load current for CH A and B.

For the 2+ or 2- load parallel operation, user should make a wire connection from each load channel input to power supply output.

DUAL

Purpose:

Setting the Dual voltage or Dual current meter display of the SLD-series electronic load module.

Command Syntax:

SLD Modules: DUAL{SP}{DVM|DAM|OFF}{;|NL}

Description:

The Dual V/A command is not controlled by CH A/B operation; it is an independent command

operation. This command is used for dual voltage meter or current meter to be displayed on the two 5-digit LED displays.

DUAL DVM; To set the meter is in dual voltage meter mode, the engineering unit is "V".

DUAL DAM; To set the meter is in dual current meter mode, the engineering unit is "A".

DUAL OFF; Disable the dual meter function, the upper 5-digit LED display is voltage meter, the lower 5-digit LED display is current meter.

5.4.2 Query Commands

CHANNEL

Purpose:

The active channel query command.

Command Syntax:

System: CHAN ? {NL}

Description:

CHAN ? return the active channel, "1-4" indicate the active channel is channel "1-4".

CURRENT Level

Purpose:

The Constant Current mode's load current level query command.

Command Syntax:

All SLM Modules: CC:{HIGH|LOW}{?};|NL}

SLD Modules: CC{?};|NL}

Description:

CURR:LOW? return the presently programmed low load current level in Constant Current mode of SLM-series DC or AC electronic load module.

CURR? return the presently programmed load current level in Constant Current mode of SLD-series electronic load module.

RESISTANCE Level

Purpose:

The Constant Resistance mode's load resistance level query command.

Command Syntax:

All SLM Modules: CR:{HIGH|LOW}{?};|NL}

SLD Modules: CR{?};|NL}

Description:

RES:LOW? returns the presently programmed low load resistance level in Constant Resistance mode of SLM-series DC or AC electronic load module.

RES? returns the presently programmed load resistance level in Constant Resistance mode of SLD-series electronic load module.

The engineering unit is "OHM".

VOLTAGE Level

The Constant Voltage mode's load voltage level query command.

Command Syntax:

SLM DC Modules: CV:{LOW|HIGH}?{NL}

SLD Modules: CV:{NL}

Description:

CV:LOW? return the presently programmed low load voltage level in Constant Voltage mode of SLM DC electronic load module.

CV:HIGH? return the presently programmed high load voltage level in Constant Voltage mode of SLM DC electronic load module.

The engineering unit is "V".

POWER Level

The Constant Power mode's load power level query command.

Command Syntax:

SLM DC Modules: CP:{LOW|HIGH}?{NL}

Description:

CP:LOW? return the presently programmed low load power level in Constant Power mode of SLM DC electronic load module.

CP:HIGH? return the presently programmed high load power level in Constant Power mode of SLM DC electronic load module.

The engineering unit is "W".

LOAD ON/OFF**Purpose:**

LOAD ON or LOAD OFF status query command.

Command Syntax:

All Modules: LOAD?{NL}

Description:

LOAD? returns the present load status, "0" indicates LOAD OFF, and "1" indicates LOAD ON.

LOAD ON Voltage**Purpose:**

LOAD ON voltage level query command.

Command Syntax:

SLM DC, SLD Modules: LDON?{;|NL}

Description:

LDON? returns the present load on voltage of SLD-series electronic load module.

LOAD OFF Voltage**Purpose:**

LOAD OFF voltage level query command.

Command Syntax:

SLM DC, SLD Modules: LDOF?{;|NL}

Description:

LDOF? returns the present load off voltage of SLD-series electronic load module.

LEVEL HIGH/LOW**Purpose:**

Static mode's LEVEL low or high status query command or active LEVEL of AC electronic load query command.

Command Syntax:

SLM Modules: LEVE?{NL}

Description:

LEVE? returns the present level status, "0" indicates LEVEL LOW, and "1" indicates LEVEL HIGH.

PRESET ON/OFF**Purpose:**

PRESet ON or OFF status query command.

Command Syntax:

All Modules: PRES?{NL}

Description:

PRES? returns the present preset status, "0" indicates PRESet OFF, and "1" indicates PRESet ON.

MODE**Purpose:**

CC, CR, CV or CP operating mode query command.

Command Syntax:

All Modules: MODE?{NL}

Description:

MODE? returns the present operating mode status, "0" indicates CC MODE, "1" indicates CR MODE, and "2" indicates CV MODE, "3" indicates CP MODE.

CV MODE is available DC electronic loads (except 500V models).

CP MODE is available in SLM DC electronic load modules.

NAME**Purpose:**

Electronic Load module model number query command.

Command Syntax:

All Modules: NAME?{NL}

Description:

NAME? return the active Electronic Load channel's model number.

PROTECTION Status Register**Purpose:**

OPP, OTP, OVP, and OCP protection status query command.

Command Syntax:

All Modules: PROT?{NL}

setting current = 20.0 A
actual setting current = 3.071 A
bit 0 will set to high

bit 1:Range Changed

This bit set to high by Electronic Module Load setting command causing change range.
Reset by CLER command.

Example:

SLM-60-30-150
FALL 0.050 MA
FALL 100.0 MA
setting fall time to 100.0 MA will change range then bit 1 will set to high.

bit 2 :invalid command

This bit set to high by accepted illegal command.

bit 3 :invalid operating

This bit set to high by accepted invalid operating command.

Example:

SLM-60-30-150
MODE CR
DYN ON
DYNAMIC function only supports CC MODE.

VOLTAGE METER**Purpose:**

The reading of 4 1/2 digit voltage meter read back query command.

Command Syntax:

All Modules: MEAS:VOLT?{NL}

Description:

MEAS:VOLT? returns the present 4 1/2 digital voltage meter reading. The returned data format is shown in Table 4-2, the engineering unit is "V".

CURRENT METER**Purpose:**

The reading of 4 1/2 digit current meter read back query command.

Command Syntax:

All Modules: MEAS:CURR?{NL}

Description:

MEAS:CURR? returns the present 4 1/2 digital current meter reading. The engineering unit is "A."

POWER METER**Purpose:**

To read the value of Watt meter.

Command Syntax:

SLM Modules: MEAS:POW?{;|NL}

Description:

MEAS:POW? Reads back the value of 4 digit of the Watt meter; unit is (W).

VA METER**Purpose:**

To read the value of VA meter.

Command Syntax:

SLM AC Modules: MEAS:VA?{;|NL}

Description:

MEAS:VA? Reads back the value of 4 digit of VAmeter, unit is (VA).

GLOB:GLOBAL (All channels active at the same time)

If a channel does not have a module installed, read back will be 9999, to input buffer.

GLOB:MEAS:VOLT**Purpose:**

The reading of 4 1/2 digit voltage meter from channel 1 to channel 4 read back query command.

Command Syntax:

All Modules: GLOB:MEAS:VOLT?{NL}

Description:

GLOB:MEAS:VOLT? returns the present 4 1/2 digital voltage meter reading from channel 1 to channel 4 respectively. The returned data format is shown in Table 4-2, the engineering unit is "V".

Example:

GLOB:MEAS:VOLT?

read back data is 4.998, 12.002, 9999., 11.998 where channel 1 voltage is 4.998V, channel 2 voltage is 12.002V, channel 3 is non-installed, channel 4 voltage is 11.998V.

GLOB:MEAS:CURR**Purpose:**

The reading of 4 1/2 digit current meter from channel 1 to channel 4 read back query command.

Command Syntax:

All Modules: GLOB:MEAS:CURR?{NL}

Description:

GLOB:MEAS:CURR? returns the present 4 1/2 digital current meter reading from channel 1 to channel 4 respectively. The engineering unit is "A".

Example:

GLOB:MEAS:CURR?

read back data is 4.998, 3.002, 9999., 0.998 where channel 1 current is 4.998 A, channel 2 current is 3.002 A, channel 3 is non installed, channel 4 current is 0.998 A.

SYNCHRONOUS ON/OFF

Purpose:

To read the setting condition of SYNC.

Command Syntax:

SLM AC Modules: SYNC?{|NL}

Description:

SYNC? Reads back the condition of SYNC. "0" denotes OFF, "1" denotes ON.

SENSE ON/OFF

Purpose:

To read the setting condition of Sense ON or OFF.

Command Syntax:

All Modules: SENS?{|NL}

Description:

SENS? Reads back the setting condition of SENS. "0" denotes OFF, "1" denotes ON.

WATT Meter ON/OFF

Purpose:

To read the setting condition of WATT.

Command Syntax:

SLM Modules: WATT?{|NL}

Description:

WATT? Reads back the setting condition of WATT. "0" denotes OFF, "1" denotes ON.

WAVEFORM BANK

Purpose:

To read the set value of BANK

Command Syntax:

SLM AC Modules: BANK?{|NL}

Description:

BANK? Reads back the set value of BANK. 0-10 denotes waveform bank of level 0-10.

WAVEFORM

Purpose:

To read the set value of WAVE.

Command Syntax:

SLM AC Modules: WAVE?{|NL}

Description:

WAVE? Reads back the set value of WAVE. 1-5 denotes the C.F. setting of level 1-level 5.

FREQUENCY**Purpose:**

To read the set frequency of FREQ.

Command Syntax:

SLM AC Modules: FREQ?{;|NL}

Description:

Reads back the set frequency of FREQ, unit is Hz.

VOLTAGE Limit**Purpose:**

To read the set value of upper/lower limit value of threshold voltage.

Command Syntax:

All Modules: LIM:VOLT:{HIGH/LOW}?{;|NL}

Description:

LIM:VOLT:LOW? Reads back the lower limit set value of threshold voltage, unit is "volts" (V).

CURRENT Limit**Purpose:**

To read the set value of upper/lower limit value of threshold current.

Command Syntax:

All Modules: LIM:CURR{HIGH|LOW}?{;|NL}

Description:

LIM:CURR:LOW? Reads back the lower limit set value of threshold current; unit is "amps (A)".

POWER Limit**Purpose:**

To read the set value of upper/lower limit value of threshold power(W).

Command Syntax:

SLM DC Modules: LIM:POW{HIGH|LOW}?{;|NL}

Description:

LIM:POW:LOW? Reads back the lower limit set value of threshold power; unit is "watts" (W).

VA Limit**Purpose:**

To read the set value of upper/lower limit value of threshold power (VA).

Command Syntax:

SLM AC Modules: LIM:VA{HIGH|LOW}?{;|NL}

Description:

LIM:VA:LOW? Reads back the lower limit set value of threshold power, unit is (VA).

NG**Purpose:**

To read the set value of NG.

Command Syntax:

All Modules: NG?{;|NL}

Description:

NG? Reads back the condition indicating light of NG. "0" denotes that NG (NO GOOD) indicating light has been extinguished. "1" denotes that NG indicating light has been lit.

NG Enable /Disable**Purpose:**

To read NG ON/OFF setting.

Command Syntax:

SLD Modules: NGAB{?}{;|NL}

Description:

NGAB? returns the presently NG ON/OFF status, "0" indicates NG disable, and "1" indicates NG enable.

PERIOD**Purpose:**

The dynamic mode's Tlow or Thigh duration query command

Command Syntax:

SLM DC, SLD Modules: PERI:{LOW|HIGH}?{NL}

Description:

PERI:LOW? returns the presently programmed low duration time in dynamic load mode
PERI:HIGH? returns the presently programmed high duration time in dynamic load mode
The engineering unit is "msec".

RISE Time**Purpose:**

The dynamic load mode's RISE slew rate query command

Command Syntax:

SLM DC Modules: RISE?{NL}

Description:

RISE? returns the presently programmed low load current level in Constant Current mode
The engineering unit is "A/us".

FALL Time**Purpose:**

The dynamic load mode's FALL slew rate query command.

Command Syntax:

SLM DC Modules: FALL?{NL}

Description:

FALL? returns the presently programmed low load current level in Constant Current mode
The engineering unit is "A/us".

SHORT ON/OFF**Purpose:**

SHORT ON or OFF status query command.

Command Syntax:

All Modules: SHOR?{NL}

Description:

SHOR? returns the presently SHORT status, "0" indicates SHORT OFF, and "1" indicates SHORT ON.

DYNAMIC ON/OFF**Purpose:**

DYNAmic ON or OFF status query command

Command Syntax:

SLM DC, SLD Modules: DYN?{NL}

Description:

DYN? returns the presently DYNamic ON or OFF status, "0" indicates static load mode or DYNamic OFF, and "1" indicates DYNamic load mode or DYNamic ON.

This page intentionally left blank.

APPENDIX A

SLM-SERIES DC LOAD GPIB/RS-232 OPERATING FLOW CHART

The following flow chart shows the typical SLM Series chassis remote control and load current level and status setting procedures of each load module:

